



OTTO ARC

www.ottoarc.com

2013 PRODUCT CATALOG

ORBITAL WELDING ORBITAL WELDING ORBITAL WELDING ORBITAL WELDING
BEVELING BEVELING BEVELING BEVELING BEVELING BEVELING
FACING FACING FACING FACING FACING FACING



800-878-2487





OTTO ARC

INTRODUCTION

Otto Arc Systems, Inc., formerly Otto Tool, has been in business for over 25 yrs. We have been in the **Beveling and Facing (Squaring) Equipment** business since the day we opened and have been expanding our product lines ever since. Over the past two years we have added **Orbital Welding, Saws, Mechanized and Robotic products** to our choice of products.

For 2013 we are most excited about introducing our line of quick cut saw products. We have been working persistently to build our machine specifications as the best on the market, which includes a full line of **Tube and Pipe Cutting Saws**; we will also offer **Hacksaws** to cut pipe 4" to 30".

This year our new catalog will present to you how our company has grown over the years and the wide array of products we have to offer. At Otto Arc we are always making sure our clients are well taken care of - that is our first priority.

We are always attentive to new market trends and believe that feedback from our customers has placed our company on the map. We assist our clients by listening to their needs and then delivering to them the best options, service and products available for their business. Thank you for your time and consideration; please do not hesitate to contact us with any questions you may have.

Sincerely,

Alan Avis
President, Otto Arc Systems, Inc.

TABLE OF CONTENTS

ORBITAL WELDING PRODUCTS

Power Supply Units	1-4
Tube and Pipe Welding Heads	5-12
Tube Sheet Welding Heads	13-18
Custom Manufactured Products	19-20
Welding Accessories	21-22

BEVELING PRODUCTS

Beveling Machines (ID Mount)	23-28
Split Frames (OD Mount)	29-30

HEAVY DUTY HACKSAWS

Hacksaws & Pipe Clamps	31-33
Hacksaw Accessories	34

SQUARING PRODUCTS

Squaring Machines (OD Mount)	35-40
-------------------------------------	--------------

WELDING HEADS / ACCESSORIES

Saw Guides & Blades	41
Weld Heads	42-43
Accessories	43
Rental / Training/Warranty Info	44

CONTACT US!

For other power requirements, quotes or questions please contact us at 1-800-878-BITS (2487)



BITAL WELDING

ORBITAL WELDING

ORBITAL WELDING

ORBITAL WELDING

DING

ORBITAL WELDING

ORBITAL WELDING

ORBITAL WELDING

ORBITAL WELDING

RBITAL WELDING

ORBITAL WELDING

ORBITAL WELDING

ORBITAL WELDING

FEATURES

The OW-ARC 200 digital GTAW (TIG) welding power source consists of an inverter power supply, remote control pendant and integrated water-cooling system. The system utilizes a state-of-the-art PC controller. This unit is designed for thin wall pipe, tubing, and tube to tube-sheet applications. Commonly used for chemical, food, pharmaceutical, heat exchangers, semiconductor, and instrumentation tubing applications.

PERFORMANCE

- Windows CE embedded version operating system
- Up to 20 levels for each program for accurate welding control
- Internal memory can store 100 welding programs
- USB support for importing and exporting data
- Controls for welding current, travel/wire speed and gas
- Control pendant display for real-time data monitoring
- Fault detection and message display for easy maintenance
- Option to choose offline programming or offline printing
- Welding heads available for a wide range of welding applications
- Integrated water cooling system
- Solid metal case for convenient transport



OW-ARC 200 Power Unit Includes: Machine, Hoses, Manual and Case

OW-ARC 200 Auto Shift 115V - 240V 50/60Hz Single Phase

P/N: OW-ARC 200

OW-ARC 200

Type	Inverter
Current	5 - 200A
Duty Cycle	200A 60% / 155A 100%
Open Circuit Voltage	55V
Input Voltage	Auto Shift 115V - 240V 50/60Hz Single Phase
Frequency	50Hz / 60Hz Single Phase
Cooling	External water circuit
Power	5KVA
Display	Industrial PC
Functions	Gas, rotation, current and wire feeding control
Program Storage	100
Number of Levels (per program)	20
Weight (ex. coolant) kg/lbs	28kg (61.6 lbs.)
Insulation / Protection Class	F / IP21
Screen, CPU, Memory and Disk Size	6.5", 1.1G, 1G, 2G with Printer
Dimensions mm (inches)	622mm x 520mm x 406mm (24.5" x 20.5" x 16")

WATER TANK

Input Voltage	115V-220V 10%, 50/60Hz
Cooling Capacity	800W
Water Flow	8L/min / 2.1 gallon/min
Water Tank Capacity	5.5L / 1.5 Gallons
Weight (ex. coolant) kg/lbs	12kg / 26.4lbs

FEATURES

The OW-ARC 250 uses an intelligent PC basis control system with digital signal processing chips and high resolution monitoring for every output and sampling signal. It also contains a windows CE embedded version operating system and simple operating interface for accurate welding. Also includes keyboard support, mouse operation; off-line programming and off-line printing function.

PERFORMANCE

- Up to 20 levels for each program for accurate welding control
- Internal memory can store 100 welding programs
- USB support for importing and exporting data
- Controls for welding current, travel/wire speed and gas
- Control pendant display for real-time data monitoring
- Welding distance can be set according to time or degree
- Arc voltage tracking control for peak and/or base values or simultaneous values
- Oscillation edge lock function
- Memory function for welding parameter during the process
- Fault detection and message display for easy maintenance
- Pulse rotation and pulse wire feeding function
- Wire feeding ON/OFF during the welding process
- Current, rotation/wire feed speed, oscillation width and speed, center position, arc voltage and gas are adjustable during the welding process
- Data transfer between the same series power source by USB driver
- Option to choose offline programming and printing with USB support
- Welding heads available for autogenous (fusion) / wire feed applications
- Multi-axis function display
- Integrated water cooling system/Internal printer to print data and reports
- Solid metal case for convenient transport



Cover flips up to view Control/Data Display



OW-ARC 250 Power Unit Includes: Machine, Hoses, Manual and Pendant

OW-ARC 250 Electric 220v P/N: OW-ARC 250

OW-ARC 250

Type	Inverter
Current	5 - 250A
Duty Cycle	150/200A 100% / 250A 60%
Open Circuit Voltage	52V
Input Voltage	220V
Frequency	50Hz / 60Hz Single Phase
Torch Cooling	Built-in water circuit cooling
Power	8.5 KVA
Functions	Gas control, current control, rotation control, wire feeding, oscillation and arc voltage control
Program Storage	100
Number of Levels (per program)	20
Insulation / Protection Class	F / IP21
Max. Tank Capacity	15 L / 4 Gallons
Screen, CPU, Memory and Disk Size	6.5", 1.1G, 1G, 2G with Printer
Weight (ex. Coolant)	135kg / 297 lbs.
Dimensions mm (inches)	110mm x 545mm x 1120mm (43.7" x 21.45" x 44")

FEATURES

The OW-ARC 400 digital GTAW (TIG) welding power source consists of an inverter power supply, remote control pendant, integrated water cooling system and gas bottle rack on a portable chassis. The system utilizes a state-of-the-art PC controller and is designed for medium to thick wall pipe and tubing. It offers easy programming and versatility to tackle the most demanding piping applications for power generation, petrochemical, marine and aerospace industries.

PERFORMANCE

- Windows CE embedded version operating system
- Up to 20 levels of parameter control (sector/levels) per welding program
- Stores 100 welding programs in internal memory
- Parameter controls for welding current, travel speed, wire speed, shielding gas and AVC / OSC control
- Arc voltage tracking control for peak and or base value tracking or simultaneous tracking
- Welding heads available for autogenous (fusion) / wire feed applications
- Control pendant display for real-time data monitoring (save data or graphics for printing)
- Oscillation controls - width, speed and center position are adjustable during the welding process
- High frequency or touch start arc ignition
- Built in integrated water cooling system
- Comprehensive fault detection and message display for easy maintenance
- Option to choose offline programming with offline printing



Remote Pendant Control Unit



Control/Data Display



OW-ARC 400 Power Unit Includes: Machine, Hoses, Manual and Pendant

OW-ARC 400 (240V-480V 3 Phase) P/N: OW-ARC 400

OW-ARC 400

Type	Inverter
Current	5- 400A
Duty Cycle	400A, 60% / 310A, 100%
Open Circuit Voltage	72V
Input Voltage	240V-480V 3 Phase
Power	13.5KVA
Torch Cooling	Integrated water circuit
Display	Industrial PC
Functions	Gas control, current control, rotation control, wire feeding, oscillation and Arc voltage control
Program Storage	100
Number of Levels (per program)	20
Insulation / Protection Class	F/IP21
Water Tank Capacity	15L / 4 Gallons
Weight (ex. Coolant) kg /lbs	135kg / 297lbs
Dimension mm (inches)	1110mm x 545mm x 1120mm (43.7" x 21.45" x 44")

FEATURES

The OW-ARC 401 power source is designed and manufactured using advanced technology created by Otto Arc Systems. It contains a PC controller with a 32 bit Windows CE operating system which supports concentrated settings, storing and function parameters. The OW-ARC 401 is a "cold wire power source" and is used for narrow groove welds that require a large current. The cooling system is designed at two levels. The power source itself is air cooled, where the weld head is cooled using an optional external water cooling system. The OW-ARC 401 is commonly used for the thermal power, valve, coal mine, boiler and nuclear plant industries.

PERFORMANCE

- Windows CE embedded version operating system
- External USD support for importing and exporting data
- Real-time welding parameter recording during welds
- Control pendant display for real-time data monitoring (save data or graphics for printing)
- Adjustable parameters during welding process
- Time and degree exchange for weld travel and other relevant parameters
- Various built-in welding head parameters for accurate motion control
- Comprehensive fault detection and message display for easy maintenance
- Option to choose offline programming or offline printing
- Optional integrated water tank



OW-ARC 401 Power Unit Includes: Machine, Hoses, Manual and Pendant

OW-ARC 401 (240V-480V 3 Ph; P/N: OW-ARC 401)

OW-ARC 600 Power Unit Includes: Machine, Hoses, Manual and Pendant

OW-ARC 600 Electric 380v P/N: OW-ARC 600

OW-ARC 401 (Cold Wire)

Type	Inverter	Computer	PC
Current	5- 400A	Program Storage	100
Duty Cycle	400A, 60% / 310A, 100%	Number of Levels (per program)	20
Open Circuit Voltage	72V	Insulation / Protection Class	F/IP23
Input Voltage	240V-480V 3 Phase	Optional Water Cooling System	CW-04
Power	13.5KVA	Torch Cooling	External water circuit
Torch Cooling	Air Cooling	Weight (ex. Coolant) kg /lbs	260kg / 573lbs
Display	Remote control/industrial PC and Real time display	Dimensions mm (inches)	710mm x 500mm x 1500mm (28" x 19.68" x 59.6")

OW-ARC 600 (Hot Wire)

Type	Inverter	Computer	PC
Current	5- 600A	Program Storage	100
Duty Cycle	600A, 60% / 500A, 100%	Number of Levels (per program)	20
Open Circuit Voltage	72V	Insulation / Protection Class	F/IP23
Hot Wire Current	5-200A	Optional Water Cooling System	RC4
Duty Cycle for Hot Wire Current	200A, 60% / 120A, 100%	Torch Cooling	External water circuit
Input Voltage	240V-480V 3 Phase	Weight (ex. Coolant) kg /lbs	290kg / 639lbs
Power	35KVA	Dimensions mm (inches)	810mm x 600mm x 1700mm (31.8" x 23.6" x 67")
Torch Cooling	Air Cooling		
Display	Remote control/industrial PC and Real time display		

ORBITAL WELDING PRODUCTS

TPWH-C SERIES (Closed Weld Head for Tube and Pipe)

The TPWH-C series is designed to perform orbital TIG welds on tube and thin wall pipe without the need for wire feeding. The sealed cavity is filled with protective gas prior to and during the welding process. This weld head is very efficient and has a water cooled system. Various collet sizes are available, offering accurate positioning without tacking.

*Pictured:
TPWH-C-6 Closed Weld Head*

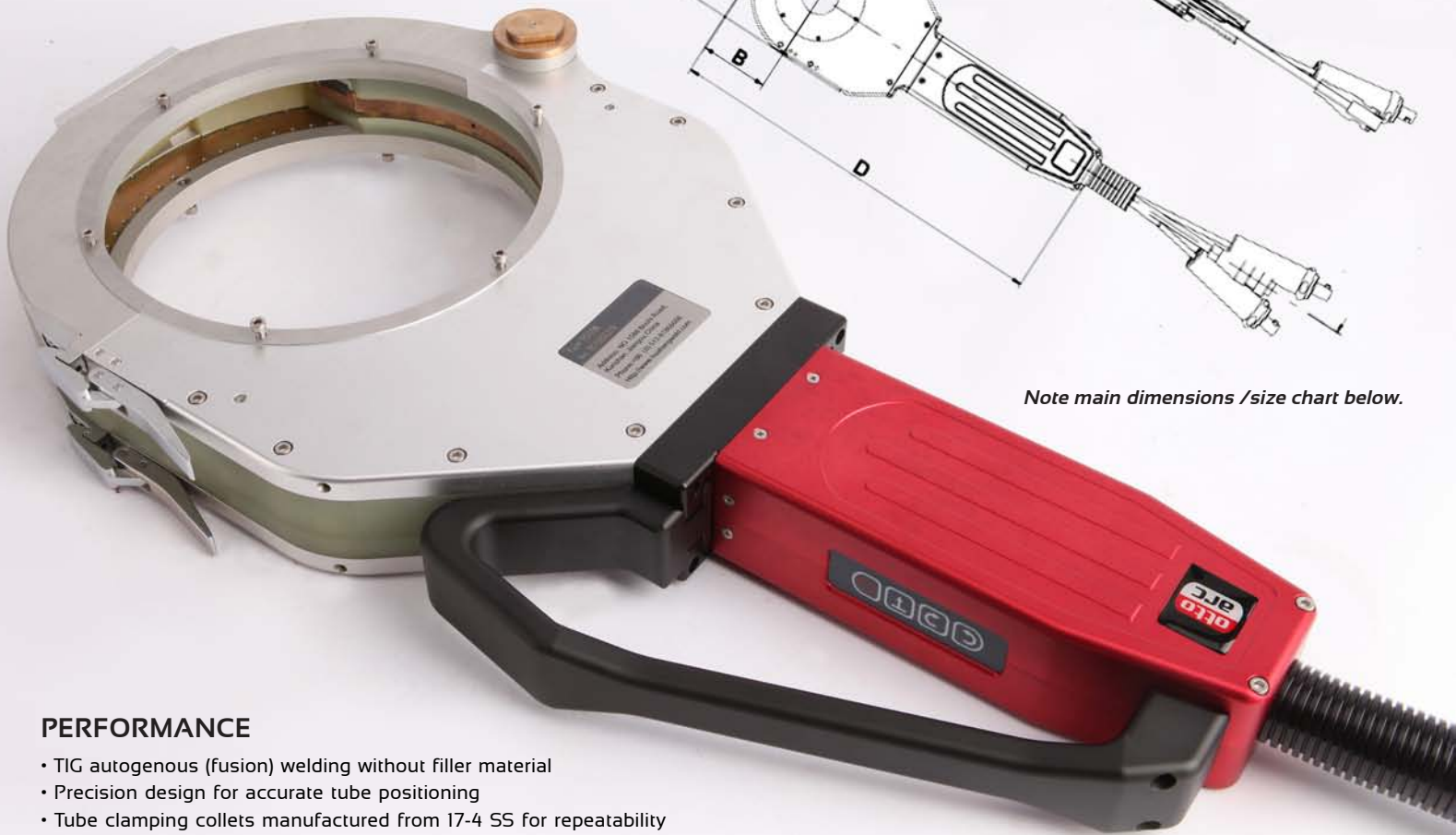

Note main dimensions /size chart below.

PERFORMANCE

- TIG autogenous (fusion) welding without filler material
- Precision design for accurate tube positioning
- Tube clamping collets manufactured from 17-4 SS for repeatability
- Closed chamber for better gas coverage and cleaner welds
- Compact design for small work areas
- Commonly used for stainless steel, nickel alloys and titanium
- Water cooled head for high production and larger wall thickness
- The tool of choice for medical, food, biological, electric, instrument and pipe installation industries
- Recommended Power Unit = OW-ARC 200

SEE FOLLOWING PAGE FOR WELD HEAD COLLETS

TPWH-C Series (Material Type: Stainless Steel and Titanium Alloy)						
	TPWH-C-5	TPWH-C-1	TPWH-C-1.5	TPWH-C-3	TPWH-C-4	TPWH-C-6
Diameter Range mm (inches)	3-12.7mm (.125"-0.5")	6-25.4mm (.25"-1")	6.35-38.1mm (.25" - 1.5")	19.05-76.2mm (.75" - 3")	38.1-101.6mm (1.5" - 4")	50.8-168mm (2" - 6.625")
Welding Speed (rpm)	2.3-46.13	0.61-12.2	0.3-6.08	0.2-4.08	0.09-1.9	0.06-1.19
Standard Cable Length	6m (20')	10m (33')	10m (33')	10m (33')	10m (33')	10m (33')
Cooling	Air	Water	Water	Water	Water	Water
Weight kg (lbs) excludes cable	0.85 (2 lbs.)	2.0 (4.4 lbs.)	2.0 (4.4 lbs.)	3 (6.6 lbs.)	6 (6.6 lbs.)	10.5 (23 lbs.)
Dimensions (mm)	280 x 85 x 45	340 x 80 x 100	360 x 120 x 41	412 x 165 x 43	497 x 230 x 57	360 x 330 x 61
Dimensions (inches)	11" x 3.4" x 1.8"	13.4" x 3.2" x 4"	14.2" x 4.8" x 1.6"	16.2" x 6.5" x 1.7"	19.5" x 9" x 2.25"	24.8" x 13" x 2.4"
Main Dimensions	mm (inches)	mm (inches)	mm (inches)	mm (inches)	mm (inches)	mm (inches)
A	65mm (2.6")	80mm (3.2")	98mm (3.9")	145mm (5.7")	195mm (7.7")	255mm (11.6")
B	35mm (1.4")	40mm (1.6")	47mm (1.9")	72mm (2.9")	97mm (3.9")	150mm (6")
C	12.5mm (0.5")	40mm (1.6")	41mm (1.6")	43mm (1.6")	57mm (2.5")	61mm (2.4")
D	280mm (11")	340mm (13.4")	360mm (14.2")	412mm (16.2")	497mm (19.5")	630mm (24.8")
E	32.5mm (1.3")	40mm (1.6")	49mm (1.95")	72.5mm (2.85")	97.5mm (3.85")	127.5mm (5.8")

COLLETS

WELD HEAD COLLETS (For TPWH-C SERIES)

TPWH-C-5 (Closed Chamber) Cassette

C-5-.125	.125" Collet for TPWH-C-5
C-5-.25	.25" Collet for TPWH-C-5
C-5-.375	.375" Collet for TPWH-C-5
C-5-.5	.5" Collet for TPWH-C-5

TPWH-C-1 (Closed Chamber)

C-1-.25	.25" Collet for TPWH-C-1
C-1-.375	.375" Collet for TPWH-C-1
C-1-.5	.5" Collet for TPWH-C-1
C-1-.5P	.5P" Collet for TPWH-C-1
C-1-.625	.625" Collet for TPWH-C-1
C-1-.75	.75" Collet for TPWH-C-1
C-1-.75P	.75P" Collet for TPWH-C-1
C-1-1	1" Collet for TPWH-C-1

TPWH-C-1.5 (Closed Chamber)

C-1.5-.25	.25" Collet for TPWH-C-1.5
C-1.5-.375	.375" Collet for TPWH-C-1.5
C-1.5-.5	.5" Collet for TPWH-C-1.5
C-1.5-.5P	.5P" Collet for TPWH-C-1.5
C-1.5-.625	.625" Collet for TPWH-C-1.5
C-1.5-.75	.75" Collet for TPWH-C-1.5
C-1.5-.75P	.75P" Collet for TPWH-C-1.5
C-1.5-1	1" Collet for TPWH-C-1.0
C-1.5-1P	1P" Collet for TPWH-C-1.5
C-1.5-1.5	1.5" Collet for TPWH-C-1.5

TPWH-C-3 (Closed Chamber)

C-3-75	3/4" Collet for TPWH-C-3 Head
C-3-75P	3/4P" Collet for TPWH-C-3 Head
C-3-1	1" Collet for TPWH-C-3 Head
C-3-1P	1"P Collet for TPWH-C-3 Head
C-3-1.5	1.5" Collet for TPWH-C-3 Head
C-3-1.5P	3/4P" Collet for TPWH-C-3 Head
C-3-2	2" Collet for TPWH-C-3 Head
C-3-2P	2P" Collet for TPWH-C-3 Head
C-3-2.5	2.5" Collet for TPWH-C-3 Head
C-3-2.5P	2.5P Collet for TPWH-C-3 Head
C-3-3	3" Collet for TPWH-C-3 Head
C-3A	Adapter 2503 for TPWH-C-3

TPWH-C-4 (Closed Chamber)

C-4-1.5	1.5" Collet for TPWH-C-4
C-4-1.5P	1.5P" Collet for TPWH-C-4
C-4-2	2" Collet for TPWH-C-4
C-4-2P	2P" Collet for TPWH-C-4
C-4-2.5	2.5" Collet for TPWH-C-4
C-4-2.5P	2.5P" Collet for TPWH-C-4
C-4-3	3" Collet for TPWH-C-4
C-4-3.5	3.5" Collet (3" Pipe) for TPWH-C-4
C-4-4	4P" Collet (3.5" Pipe) for TPWH-C-4
C-4.5A	Adapter 3503 for TPWH-C-4

TPWH-C-6 (Closed Chamber)

C-6-2	2" Collet for TPWH-C-6 Head
C-6-2P	2" Collet for TPWH-C-6 Head
C-6-2.5	2.5" Collet for TPWH-C-6 Head
C-6-2.5P	2.5P" Collet for TPWH-C-6 Head
C-6-3	3" Collet for TPWH-C-6 Head
C-6-3.5	3.5" Collet (3" Pipe) for TPWH-C-6 Head
C-6-4	4" Collet (3.5" Pipe) for TPWH-C-6 Head
C-6-4.5	4.5" Collet (4" Pipe) for TPWH-C-6 Head
C-6-6	6" Collet for TPWH-C-6 Head
C-6-6P	6P" Collet for TPWH-C-6 Head
C-6A	Adapter 4503 for TPWH-C-6

ORBITAL WELDING PRODUCTS

TC-ARC-1 (AMI) Closed Weld Head

Plugs directly into AMI Power Sources, no cable adapter needed. Optional adapter available for AMI collets, easy clamping system.



PERFORMANCE

- Plugs directly into AMI Power Unit
- No cable adapter needed
- Easy clamping system for adjusting and tightening collets
- Size range is 1/4" to 1"
- Various sized collets available
- Optional adapter available if using AMI collets (see page 42)
- Optional 1" head holder available
- Heavy duty, more robust design
- Water cooled

TC-ARC-1

Diameter Range mm (inches)	6-25.4mm (.25"-1")
Welding Speed (rpm)	0.61-12.2
Weight kg (lbs)	2.5kg (5.5lbs)
Standard Cable Length	10m (32.8')
Cooling	Water
Dimensions (mm)	337x96x50
Dimensions (inches)	13.25"x3.78"x1.97"

Main Dimensions

mm (inches)

Same as 1" TPWH-C Weld Head (see page 5)

Note: This weld held is specifically designed for AMI equipment.

ORBITAL WELDING PRODUCTS

TPWH-O SERIES (Open Weld Head for Tube and Pipe)

The TPWH-O Series is designed for TIG welding on tube to tube, pipe to pipe and pipe fittings and is suitable for carbon and stainless steel. The TPWH-O Series is used for applications that do not require AVC/OSC. Welds tubing and pipe for industries such as chemical, food, medicine, boilers, military and nuclear industries.

Cable Details for all O Series:

Rotation L=7m (23')

Water, electric assay (050000-2400-0000-00)

Meters L=7m+3m Feet L=23'+10'

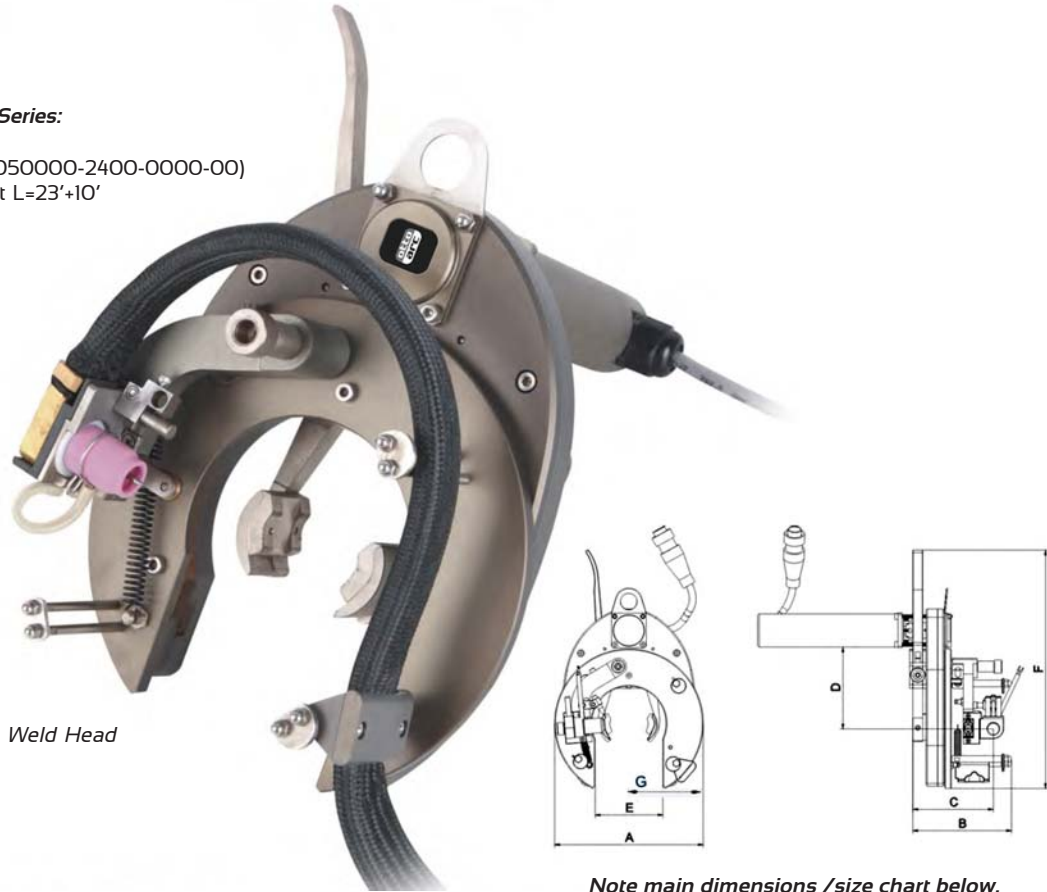

Pictured:
TPWH-O-5 Open Weld Head

Note main dimensions /size chart below.

PERFORMANCE

- Suitable for thin wall stainless steel, carbon steel and other common alloys
- Capable of welding 4mm (.158") wall thickness
- Used for tube to tube, tube to flange, tube to elbow and tube to valve etc.
- Automatic all position TIG welding for tube to tube welding with or without wire feed
- Water cooled and highly durable torch design
- Mechanical tracking ensures consistent torch height control
- **Recommended Power Unit = OW-ARC 200**

TPWH-O Series			
	TPWH-O-1	TPWH-O-3	TPWH-O-5
Tube OD	Inner Clamp: 15-25mm (.625"-1") Outer Clamp: 25-43mm (1"-1.625")	Inner Clamp: 19.05-45mm (.75"-1.75") Outer Clamp: 45-77mm (1.75"-3")	Inner Clamp: 38.1-76mm (1.5"-3") Outer Clamp: 76-130mm (3"-5")
Tungsten Diameter	2.4mm (3/32")	2.4mm (3/32")	2.4, 3.2mm (3/32", 1/8")
Rotation Speed (rpm)	0.37-7.45	0.19-3.8	0.11-2.2
Protective Gas	Ar / Mixed Gases	Ar / Mixed Gases	Ar / Mixed Gases
Cooling	Water	Water	Water
Cooling Flow (ml/mm)	≥600	≥600	≥600
Weight kg (lbs)	2.5kg (5.5lbs) excludes cable	4kg (9lbs) excludes cable	10.8kg (23lbs) excludes cable
Dimensions (mm)	305 x 128 x 230mm	310 x 180 x 290mm	435 x 300 x 400mm
Dimensions (inches)	12" x 5" x 9"	12" x 7" x 11"	17"x12"x15.5"
Main Dimensions	mm (inches)	mm (inches)	mm (inches)
A	128mm (5.04")	180mm (7.09")	300mm (11.8")
B	115mm (4.5")	120mm (4.75")	235mm (9.25")
C	85.5-92.5mm (3.37"-3.64")	95-101mm (3.75"-4")	132-172mm (5.2"-6.77")
D	165mm (6.5")	92mm (3.62")	165mm (6.5")
E	44mm (1.73")	82mm (3.23")	132mm (5.2")
F	231mm (9.09")	290mm (11")	400mm (15.5")
G	64mm (2.52")	60mm (3.545")	150mm (5.9")

TPWH-OA SERIES (Open Weld Head with AVC and OSC for Tube and Pipe)

The TPWH-OA Series is designed for TIG welding on tube to tube, pipe to pipe and pipe fittings and is suitable for carbon and stainless steel. The TPWH-OA Series is used for applications that require AVC/OSC. Welds tubing and pipe for industries such as chemical, food, medicine, boilers, military and nuclear industries.

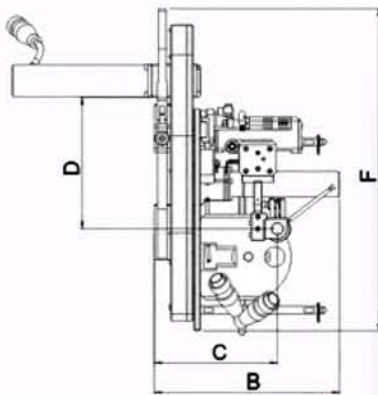
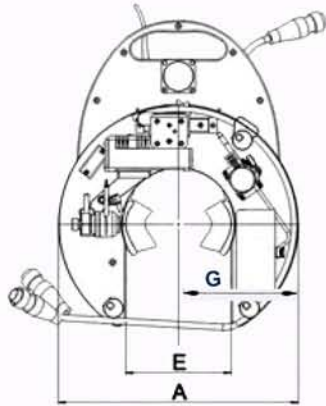

Pictured:
TPWH-OA-7 Open Weld Head internal or external wire feeder accessory available for the TPWH-OA Series

Cable Details for all OA Series:
Rotation and AVC Cable L=7m (23')
Water, electric assay (050000-2400-0000-00)
Meters L=7m+3m Feet L=23'+10'



Example of Pipe Weld:
4" Carbon Steel, Sch 80

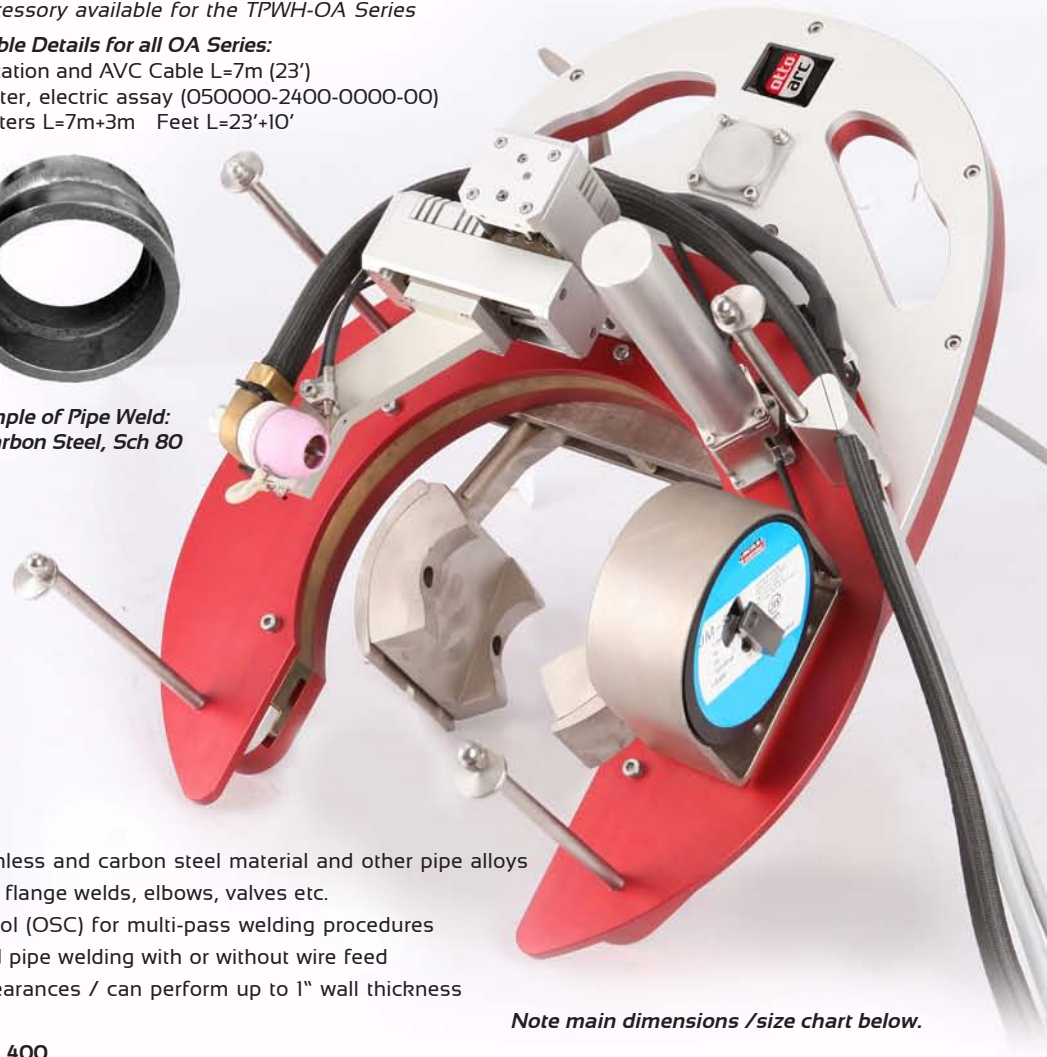

Note main dimensions /size chart below.

PERFORMANCE

- Commonly used for medium to thick wall stainless and carbon steel material and other pipe alloys
- Used for pipe to pipe, tube to tube, butt welds, flange welds, elbows, valves etc.
- Arc voltage control (AVC) and oscillation control (OSC) for multi-pass welding procedures
- Automatic all position TIG welding for tube and pipe welding with or without wire feed
- Compact design for limited radial and axial clearances / can perform up to 1" wall thickness
- Water cooled and highly durable torch design
- **Recommended Power Unit = OW-ARC 250 and 400**

TPWH-OA Series	TPWH-OA-3	TPWH-OA-5	TPWH-OA-7	TPWH-OA-9	TPWH-OA-12
Tube OD	Inner Clamp: 19.05-45mm (.75"-1.75") Outer Clamp: 45-77mm (1.75"-3")	Inner Clamp: 38.1-76mm (1.5"-3") Outer Clamp: 76-130mm (3"-5")	Inner Clamp: 50.8-114.3mm (2"-4.5") Outer Clamp: 114.3-180mm (4.5"-7")	Inner Clamp: 120-178mm (4.5"-7") Outer Clamp: 178-230mm (7"-9")	Inner Clamp: 150-230mm (6"-9") Outer Clamp: 230-324mm (9"-12.75")
Tungsten Diameter	2.4, 3.2mm (3/32", 1/8")	2.4, 3.2mm (3/32", 1/8")	2.4, 3.2mm (3/32", 1/8")	2.4, 3.2mm (3/32", 1/8")	2.4, 3.2mm (3/32", 1/8")
Rotation Speed (rpm)	0.19 - 3.8	0.11-2.2	0.09-1.8	0.05-1.0	0.026-0.52mm
Protective Gas	Ar / Mixed Gases	Ar / Mixed Gases	Ar / Mixed Gases	Ar / Mixed Gases	Ar / Mixed Gases
Cooling	Water	Water	Water	Water	Water
Cooling Flow (ml/mm)	≥600	≥600	≥600	≥600	≥600
OSC Width	20mm (.75")	40mm (1.5")	40mm (1.5")	40mm (1.5")	40mm (1.5")
AVC Height	40mm (1.5")	40mm (1.5")	40mm (1.5")	40mm (1.5")	40mm (1.5")
Wire Diameter mm (inches)	0.8, 0.9, 1.0 (0.031", 0.035", 0.039")	0.8, 0.9, 1.0 (0.031", 0.035", 0.039")	0.8, 0.9, 1.0 (0.031", 0.035", 0.039")	0.8, 0.9, 1.0 (0.031", 0.035", 0.039")	0.8, 0.9, 1.0 (0.031", 0.035", 0.039")
Max Wire Feed Speed	1800mm/min (5.5in/min)	1800mm/min (5.5in/min)	1800mm/min (5.5in/min)	1800mm/min (5.5in/min)	1800mm/min (5.5in/min)
Weight kg (lbs)	5.5kg (12lbs) excludes cable	10.8kg (23lbs) excludes cable	19.5kg (43lbs) excludes cable	21.5kg (47lbs) excludes cable	36kg (79lbs) excludes cable
Dimensions (mm)	370 x 220 x 320mm	435 x 300 x 400mm	445 x 375 x 525mm	465 x 425 x 570mm	430 x 610 x 680mm
Dimensions (inches)	14.5" x 8.6" x 12.5"	17" x 12" x 15.5"	17.5" x 14.5" x 20"	18" x 16.5" x 22"	17" x 24" x 26.5"
Main Dimensions	mm (inches)	mm (inches)	mm (inches)	mm (inches)	mm (inches)
A	220mm (8.66")	300mm (11.8")	375mm (14.75")	425mm (16.73")	550mm (21.65")
B	180mm (6")	235mm (9.25")	260 (10.25")	300 (11.5")	312mm (12.3")
C	112-132mm (4.41"-5.2")	132-172mm (5.2"-6.77")	184-224mm (7.24"-8.82")	194.5-234.5mm (7.65"-9.23")	228.5-268.5mm (8.9"-10.57")
D	92mm (3.6")	165mm (6.5")	225mm (8.85")	249mm (9.8")	297mm (11.7")
E	82mm (3.23")	132mm (5.2")	184mm (7.24")	230mm (9.06")	328mm (12.9")
F	320mm (14.5")	400mm (15.5")	525mm (20")	570mm (22")	680mm (26.5")
G	110mm (4.33")	150mm (5.9")	187.5mm (7.375")	212.50mm (8.365")	275mm (10.825")

ORBITAL WELDING PRODUCTS

TPWH-NS-2 (Narrow Space Weld head for Tube and Pipe)

The TPWH-NS-2 is designed for tube to "U" shape (return bends) TIG welding suitable for carbon and stainless steel tube to tube connections and is used mainly for applications that require wire feeds or autogenous welding. This product also includes an integrated wire feeder with AVC & OSC controls.

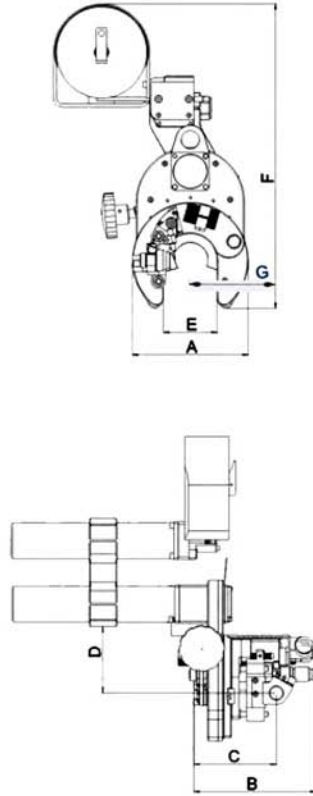

*Pictured:
TPWH-NS-2 Narrow Space
Weld Head*



Note main dimensions / size chart below.

PERFORMANCE

- Orbital welding head with integrated wire feed
- Unique no twist cable / hose design
- Motorized AVC and OSC control for narrow spaced applications
- Quick clamping and accurate centering ensure repeatability
- Special design for return bends, "S" bends and other reduced clearance applications
- **Recommended Power Unit = OW-ARC 250 or 400**

TPWH-NS-2

Diameter Range mm	32-51mm (1.26"-2")
Tungsten Diameter	2.4, 3.2mm (3/32", 1/8")
Wire Diameter	0.8, 0.9, 1.0 (0.030", 0.035", 0.040")
Standard Cable Length	L=15m (50')
Rotation Speed (rpm)	0.25 - 5.02
Weight kg (lbs)	7.5kg (15.5lbs)
Cooling	Water

Main Dimensions	mm (inches)
A	128mm (5.04")
B	138mm (5.43")
C	85-97mm (3.25"-4")
D	75mm (2.95")
E	59mm (2.32")
F	360mm (14")
G	64mm (2.52")

PWH-LD TIG (Large Diameter for Medium/Heavy Wall Pipe)

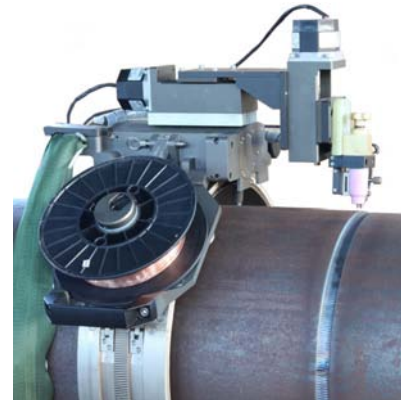

PERFORMANCE

- TIG orbital welding system for medium and heavy wall pipe
- Track mounted welding head with single/dual wire feed
- Optional with hot wire TIG welding power source and hot wire TIG wire feeder for greater performance
- Welds large diameter and thick wall stainless steel pipe welding with standard J or compound preps
- Standard "V" prep on carbon steel only
- **Recommended Power Unit = OW-ARC 250 or 400**

PWH-LD SERIES (TIG)

	PWH-LD
Diameter Range mm (inches)	203.2 -1219.2mm (8" to 48")
OSC Width mm (inches)	50mm (2")
OSC Speed mm/min (inches/min)	30mm (1.18")
AVC Speed mm/min (inches/min)	20-1000mm (.79"-39.4")
Arc Length Height mm (inches)	10 - 500mm (.39"-19.7")
Standard Cable Length	L=15m (50')
Torch Angle	-45° - +45°
Tungsten Diameter (mm)	2.4, 3.2, 4.0mm (3/32", 1/8", 5/32")
Welding Speed mm/min (inches/min)	20-400mm/min (.79"-15.7"/min)
Wire Feeding Speed (mm/min)	Cold 95-1500mm Hot 360-7800mm
Wire Feeding Speed (inches/min)	Cold 3.7-59" Hot 14.2" - 307"
Wire Diameter (mm/inches)	0.8, 0.9, 1.0, 1.2 (0.030", 0.035", 0.040",
Carriage Weight kg (lbs) <i>exc. wire and cables</i>	9kg (20lbs)

Guide Track Size	Diameter Range mm (inches)	Guide Track Size	Diameter Range mm (inches)
P/N PWH-10 (8" PIPE TO 10" PIPE)	203.2-254mm (8" to 10")	P/N PWH-30 (28" PIPE TO 30" PIPE)	711.2 - 762mm (28" to 30")
P/N PWH-12 (10" PIPE TO 12" PIPE)	254-304.8mm (10" to 12")	P/N PWH-32 (30" PIPE TO 32" PIPE)	762 - 812.8mm (30" - 32")
P/N PWH-14 (12" PIPE TO 14" PIPE)	304.8-355.6mm (12" to 14")	P/N PWH-34 (32" PIPE TO 34" PIPE)	812.8 - 863.60mm (32" to 34")
P/N PWH-16 (14" PIPE TO 16" PIPE)	355.6 - 406.4mm (14" - 16")	P/N PWH-36 (34" PIPE TO 36" PIPE)	863.60 - 914.4mm (34" to 36")
P/N PWH-18 (16" PIPE TO 18" PIPE)	406.4 - 457.2mm (16" - 18")	P/N PWH-38 (36" PIPE TO 38" PIPE)	914.4 - 965.2 (36" - 38")
P/N PWH-20 (18" PIPE TO 20" PIPE)	457.2 - 508mm (18" - 20")	P/N PWH-40 (38" PIPE TO 40" PIPE)	965.2 - 1016mm (38" - 40")
P/N PWH-22 (20" PIPE TO 22" PIPE)	508 - 558.8mm (20" - 22")	P/N PWH-42 (40" PIPE TO 42" PIPE)	1016 - 1066.8mm (40" - 42")
P/N PWH-24 (22" PIPE TO 24" PIPE)	558.8 - 609.6mm (22" - 24")	P/N PWH-44 (42" PIPE TO 44" PIPE)	1066.8 - 117.6mm (42" - 44")
P/N PWH-26 (24" PIPE TO 26" PIPE)	609.6 - 660.4mm (24" - 26")	P/N PWH-46 (44" PIPE TO 46" PIPE)	117.6 - 1168.4mm (44" - 46")
P/N PWH-28 (26" PIPE TO 28" PIPE)	609.6 - 711.2mm (24" - 26")	P/N PWH-48 (46" PIPE TO 48" PIPE)	1168.4 - 1219.2mm (46" - 48")

Larger sizes available upon request.

ORBITAL WELDING PRODUCTS

HCW TIG NARROW GROOVE (IG/5G Hot or Cold Wire Welding System)

This system contains a swinging angle torch, protective gas hood, wire feeding frame, and optional camera monitoring system and electronic sliding function. The torch is made of high temperature resistant material and integrated water cooling system and protective gas channels. The inner protective gas hood is made of stainless steel. The torch design protects the external surface while performing the groove weld.



PERFORMANCE

- Suitable for narrow bevel widths greater than 9mm (.375") and wall thickness greater than 30mm (1.25")
- Deposits heat efficiently, low heat input
- Various welding methods: horizontal, vertical and orbital welding
- Five water cooling channels, high duty cycle
- Double gas protection ensures greater weld quality
- Suitable for carbon/stainless steel, nickel base alloys and titanium pipe
- Recommended power unit = OW-ARC 400, 401 and 600

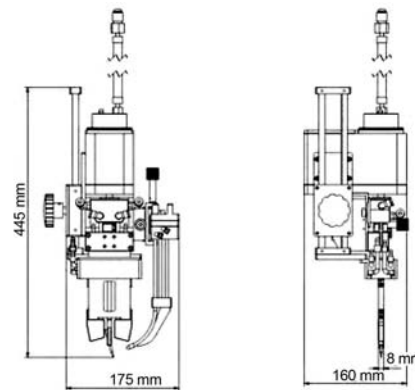

Can be configured per customer requirement.

HCWTIG NARROW GROOVE

Bevel Type	U, J type
Pipe Thickness	30-200mm (1.25"-7.75")
Bevel Width	9-20mm (.35"-.75")
Max Current (A)	350
Max Wire Feeding Speed (mm/min)	5500mm (18')
Wire Diameter	1.0, 1.2mm (0.040", 0.045")
Protective Gas	Ar / Mixed Gases
Weight	7kg / 15.43 lbs.
Cooling	Water
Dimensions mm (inches)	175 x 160 x 445 (6.88" x 6.29" x 17.5")

For track specifications, please see previous page.

The PWHM-LD is specially designed for pipe to pipe automatic MIG welding. This system is used for filling and covering pass welds for pipe with an OD greater than 12" (300mm). Support equipment: PHOENIX COLDARC Series Welding Power Source. Suitable for applications such as pipe installations and factory prefabrication.

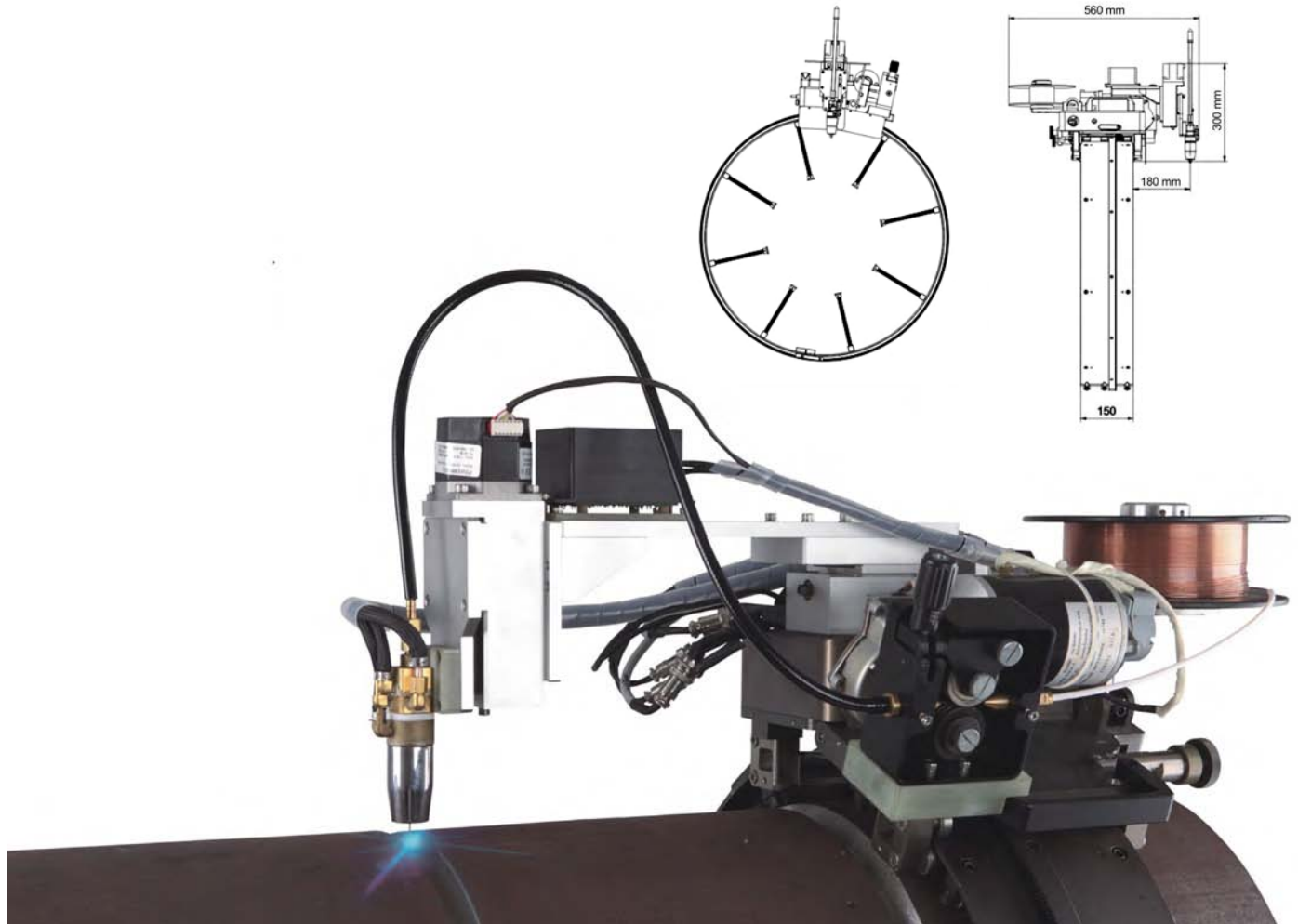

PERFORMANCE

- Contains gear transmission and stable rotation speed
- Double water cooling system suitable for filling large and heavy pipe
- Short distance wire feeding to ensure stable feed
- Various welding guides to perform welds on different size OD pipe

PWHM-LD SERIES (MIG)

	PWHM-LD
Pipe Diameter (OD)	300-1500mm (12"-60")
Rotation Speed	40-500mm (1.5"-19.68")
OSC Width	50mm (2")
AVC Height	50mm (2")
Standard Cable Length	L=15m (50')
Cooling	Circuit water cooling

For further track specifications, please contact our corporate office or Otto Arc sales representative.

ORBITAL WELDING PRODUCTS

TSWH-1.25 (Tube to Tube Sheet Weld Head)

The TSWH-1.25 tube to tube sheet weld head is designed for TIG welding small tube to tube sheet, suitable for carbon and stainless steel. It can also be used for recessed, projected and flush tubing, with or without wire feed.

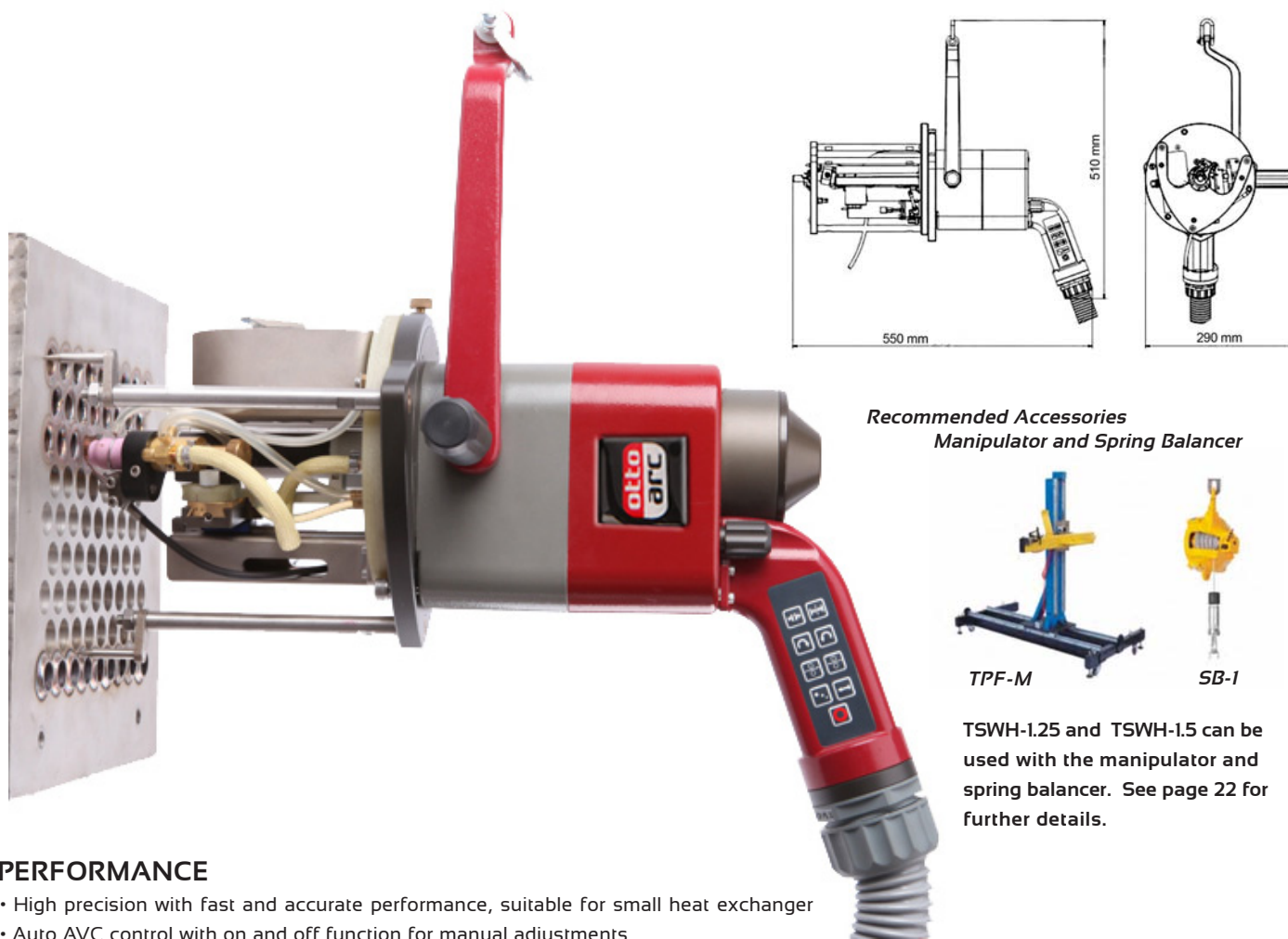

*Recommended Accessories
Manipulator and Spring Balancer*



TPF-M

SB-1

TSWH-1.25 and TSWH-1.5 can be used with the manipulator and spring balancer. See page 22 for further details.

PERFORMANCE

- High precision with fast and accurate performance, suitable for small heat exchanger
- Auto AVC control with on and off function for manual adjustments
- Water cooled TIG weld head, easy to change or adjust Tungsten
- No twist wire and special wire feeding design for accurate/repeatable single and multi pass welds
- Integrated wire feed for recessed, projected or flush tube ends
- Uses localized guide for self-centering of welds 1"OD and under, the manipulator is recommended
- Expandable mandrels to be used with optional spring balancer for welds 1"OD or larger
- Buttons on handle, simple to operate
- **Recommended power unit = OW-ARC 250 or 400**

TSWH-1.25

Diameter Range mm (inches)	8-32mm (.375"-1.25")
Rotation Speed (rpm)	0.37 - 7.39rpm
Arc Adjusting Distance	18mm (0.71")
Weight	11kg (24 lbs) without cable
Standard Cable Length	L=12m (40')
Tungsten Diameter	2.4mm (3/32")
Max wire feeding speed	1800mm (5.8')
Wire Diameter	0.8, 0.9, 1.0 (0.030", 0.035", 0.040")
Cooling	Water
Cooling flow (ml/min)	≥600 / ≥1.26 gal
Protective Gas	Ar / Mixed Gases
Duty Cycle	300A at 60%
Dimensions (mm)	550 x 290 x 510mm (21" x 11" x 20")

ORBITAL WELDING PRODUCTS

TSWH-1.5 (Tube to Tube Sheet Weld Head)

Designed for TIG welds for tube to tube sheet carbon and stainless steel. Mainly used for flush tube connections that require no wire feed.

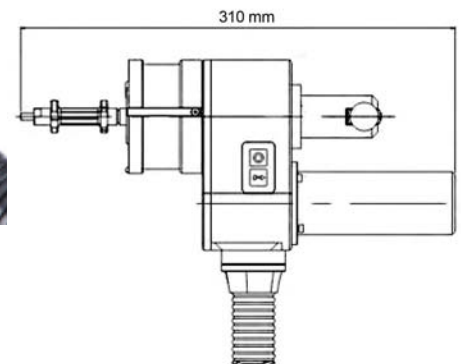
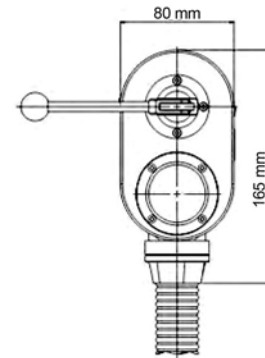

PERFORMANCE

- Tube to tube sheet welding without filler wire
- Commonly used for stainless steel, titanium and nickel alloy tube to tube sheet welding
- Small, light and simple operation
- Uses localized guide for self-centering with optional spring balancer
- Expandable centering mandrel designed for precise positioning
- Enhanced water cooling system and high duty cycle for durability
- **Recommended power unit = OW-ARC 200, 250 or 400**

TSWH-1.5

Diameter Range mm (inches)	16-38mm (.63"-1.5")
Rotation Speed (rpm)	0.6 - 12rpm
Weight kg (lbs)	3.5kg (8lbs)
Cooling	Water
Protective Gas	Ar / Mixed Gases
Standard Cable Length	L=12m (40')
Joint Type	Flush
Tungsten Diameter	2.4mm (3/32")
Welding Degree	0° - 7°
Duty Cycle	100A at 70%
Dimensions (mm)	310 x 80 x 165mm (12" x 3.15" x 6.5")

Optional Protective Cap Accessory for TSWH-TA-1.5 or TSWH-3 for Titanium Alloy Welds

- The perfect solution to titanium alloy tube to tube sheet welding with wire feed
- Dual gas protection to achieve perfect welding results, 100% repeatability
- Water cooling system for torch and mandrel to ensure effective welds and to prevent oxidation
- **Recommended power unit = OW-ARC 200, 250 or 400**

TSWH-TA-1.5

Diameter Range mm (inches)	16-38mm (.63"-1.5")
Rotation Speed (rpm)	0.414 - 8.28rpm
Torch Height Adjustment mm (inches)	20mm (.79")
Wire Feeding Speed mm/min (inches/min)	2200mm/min (87"/min)
Welding Current	300A
Standard Cable Length	L=12m (40')
Protective Gas	Ar / Mixed Gases
Gas Protection Method	Nozzle and Gas Chamber

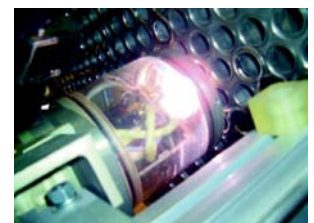

ORBITAL WELDING PRODUCTS

TSWH-3 (Tube to Tube Sheet Weld Head)

The TSWH-3 tube to tube sheet weld head is designed for TIG welding tube to tube sheet, suitable for carbon and stainless steel. It can also be used for recessed, projected and flush tubing with or without wire feed. We recommend for pipe with an OD of less than 1.25" with manipulator/balancer. For pipe with OD more than 1.25" the self centering mandrel is used with our optional spring balancer.

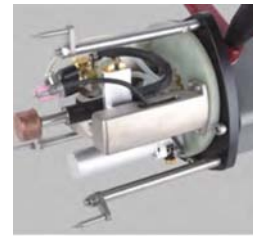
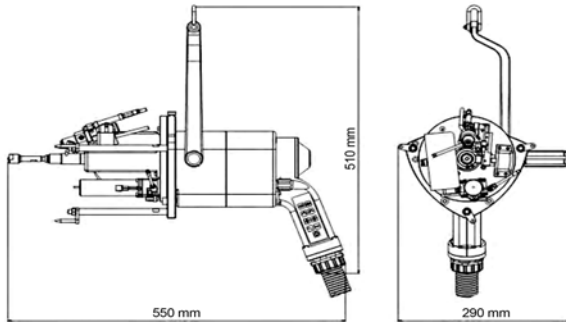

Welding Titanium? See our optional protective cap accessory on page 14.



PERFORMANCE

- With/without wire feeding TIG DC/pulse welding
- Continuous rotation weld head with no cable twist
- Suitable for Tungsten electrodes 1/16 up to 1/8
- Expandable pneumatic mandrel for easy positioning
- Easily connects to the balancer
- Suitable for tube to tube sheet welding (boiler industry)
- Compatible with manipulator - useful within the heat exchange industry
- Material types - carbon and stainless steel, and other alloys
- For flush tube, recessed (1 mm max.) and projected (not over 5mm) tube end
- Arc voltage control (AVC) for consistent torch height
- **Recommended power unit = OW-ARC 250 or 400**

Recommended Accessories Manipulator and Spring Balancer



TSWH-3

Diameter Range mm (inches)	16-60mm expandable to 80mm (.630"-2.36" expandable to 3.15")
Rotation Speed (rpm)	0.37 - 7.39rpm
Arc Voltage Adjustment mm (inches)	20mm (.79")
Welding Torch Angle	0°- 30°
Standard Cable Length	L=5m (16')
Welding Current/Duty Cycle	300A at 70%
Protective Gas	Ar / Mixed Gases
Wire Feeding Speed mm/min (inches/min)	2200mm/min (86.6"/min)
Wire Diameter mm (inches)	0.8, 0.9, 1.0 (0.030", 0.035", 0.040")
Cooling	Water
Joint Type	Flush, projected or recessed
Weight kg (lbs)	13kg (28lbs)
Dimensions	550 x 290 x 510 (22" x 11.4" x 20")

TSWH-i-75 (Tube to Tube Sheet Weld Head)

The TSWH-i-75 tube to tube sheet weld head is designed for inner tube to tube sheet TIG welding and is suitable for carbon and stainless steel without wire feed.

AUTOGENOUS / FUSION



PERFORMANCE

- Commonly used on heat exchangers, inner tube to tube sheet welding
- Minimum inner tube diameter of 19mm (.75 inches)
- Precise positioning and accurate/repeatability welding
- Suitable for carbon and stainless steel
- Can customize according to specific requirements
- Recommended power unit = OW-ARC 250 or 400

TSWH-i-75

Tube OD	±19mm (.75")	Weight (excludes cable)	11kg (24lbs)
Depth for Inner Tube	20-120mm (.75"-4.75')	Cooling Flow	≥600ml
Tube Thickness	1-2.5mm (0.040"-0.1")	Cooling	Water
Connection	Tube insert, flush tube	Standard Cable Length	L=5m (16')
Rotation Speed (rpm)	0.37 - 7.39 rpm		
Tungsten Diameter	2.4mm (0.095")		
Arc Adjusting Distance	15mm (0.59')		
Protective Gas	Ar / Mixed Gases		

TSWH-i-1 (Tube to Tube Sheet Weld Head)

This welding head is also designed for inner tube to tube sheet TIG welding with integrated wire feeder.

PERFORMANCE

- Inner-hole with integrated wire feed
- No wire twisting with special wire feed design
- Minimum inner tube diameter of 25mm (1 inch)
- Achieves complex single and multi layer welds
- Can customize according to specific requirements
- Special water cooling feature (cools to the end of torch, near the Tungsten)
- Recommended power unit = OW-ARC 250 or 400

Sample diagram of inner tube workpiece

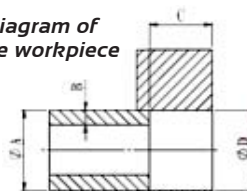

- A. Tube OD
- B. Tube thickness
- C. The distance between tube sheet and welding position
- D. Tube-sheet hole diameter



TSWH-i-1

Tube OD	≥25mm (1")	Weight (excludes cable)	12kg (26lbs)
Depth for Inner Tube	20-80mm (.75"-3')	Cooling Flow	≥600ml
Connection	Tube insert, flush tube	Cooling	Water
Tungsten Diameter	2.4mm (3/32")	Standard Cable Length	L=5m (16')
Rotation Speed (rpm)	0.37 - 7.39 rpm		
Arc Adjusting Distance	15mm (0.59')		
Max Wire Feed Speed	1800mm/min (5.83'/min)		
Protective Gas	Ar / Mixed Gases		

ORBITAL WELDING PRODUCTS

TSWH-HB-625 (Headerbox Tube to Tube Sheet Weld Head)

This weld head is designed for deep hole tube to tube sheet TIG welding. It is suitable for carbon steel, stainless steel and most TIG type materials.



PERFORMANCE

- Commonly used for special heat exchanger needs within the chemical industry (for example: air-cooled hydrogenation)
- Perfect for wire feed welds in hard to reach areas
- Narrow space welds reaching 4.75" to 8.5" (4.75" to 8.5" is the min. and max. distance between the two tube plates)
- Can customize according to specific requirements
- Torch angle negative 3 degrees
- Optional external or integrated wire feed available see page 22
- **Recommended power unit = OW-ARC 250 or 400**

TSWH-HB-625

Tube OD	25 or 32mm (1"-1.25)	Weight (excludes cable)	13kg (28lbs) no cable
Depth for Inner Tube	230mm (9") Including plate thickness	Cooling Flow	≥600ml
Connection	Flush tube	Cooling	Water
Rotation Speed (rpm)	0.37 - 7.39 rpm	Duty Cycle	200A 60%
Tungsten Diameter	2.4mm (0.095")	Standard Cable Length	L=5m (16')
Torch Angle	-3°		
Arc Adjusting Distance	18mm (0.70')		
Protective Gas	Ar / Mixed Gases		

TSWH-MGH-3 (GMAW MIG/MAG Tube to Tube Sheet Weld Head)

Designed for automatic MAG tube to tube sheet welding and utilizes a fixed localizer. This weld head can be used with our optional spring balancer; allowing for a wide range of welds.

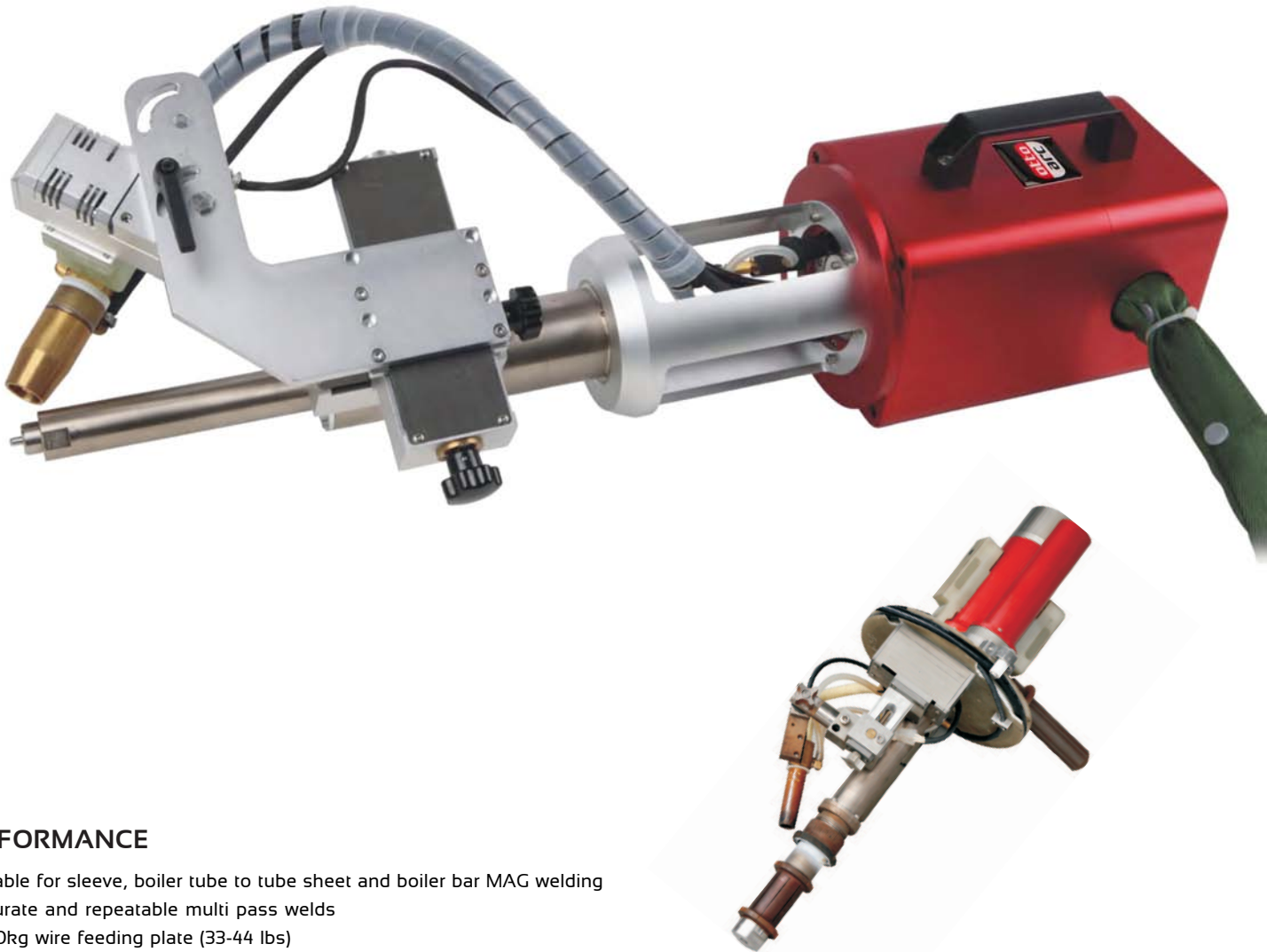

PERFORMANCE

- Suitable for sleeve, boiler tube to tube sheet and boiler bar MAG welding
- Accurate and repeatable multi pass welds
- 15-20kg wire feeding plate (33-44 lbs)
- **Recommended power unit = contact us for further information.**

TSWH-MGH-3	
Diameter Range mm (inches)	38-260mm (1.5"-10.25")
Rotation Speed (rpm)	0.23 - 4.6rpm
Torch Angle	0-60 degrees
Protective Gas	Ar / Mixed Gases
Cooling	Water
Cooling Flow (ml/min)	≥600
Duty Cycle	320A 60%
OSC Width	40mm (1.5")
Manual Adjusting Height (up and down)	40mm (1.5")
Wire Diameter	1.0, 1.2mm (0.039", 0.047")
Weight kg (lbs)	15kg (33lbs)
Standard Cable Length	L=12m (40')

ORBITAL WELDING PRODUCTS

TPH-WH-S (HORIZONTAL/VERTICAL WELD STATION)

CUSTOM MANUFACTURED PRODUCT - CALL US WITH YOUR REQUIREMENT!

This system is specially designed for tube to flange TIG welding. It can perform a spot, seam and orbital weld with or without wire feed. It can handle vertical or horizontal placement. Suitable for all industries.

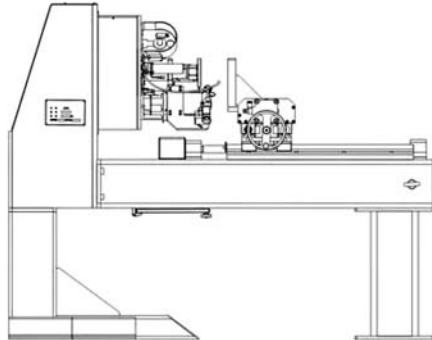

Diagram showing optional stand.



PERFORMANCE

- Pneumatic clamp design, ensures precise positioning
- Keeps workpiece stable
- Quick and convenient positioning
- Eliminates wire wrapping - reducing preparation time
- Option to choose with or without wire feed
- Water circuit cooling torch for increased working time
- **Recommended power unit = OW-ARC 250 or 400**

TPH-WH-S

Tube OD	17-76mm (.67"-3")
Tungsten Diameter	2.4mm, 3.2 mm (3/32", 1/8")
Rotation Speed (rpm)	0.1-3.29rpm
Torch Angle	0° - 45°
Protective Gas	Ar / Mixed
Cooling	Water
Cooling Flow (ml/mm)	≥600
OSC Width	40mm (1.5")
AVC Height	40mm (1.5")
Standard Cable Length	L=5m (16')
Wire Diameter	08, 0.9, 1.0mm (0.030", 0.035", 0.040")
Max Wire Feeding Speed	1800mm/min (5.83')
Weight kg (lbs)	290kg (639 lbs)

PH-O SERIES (Open Headstock for Large Pipe Welds)

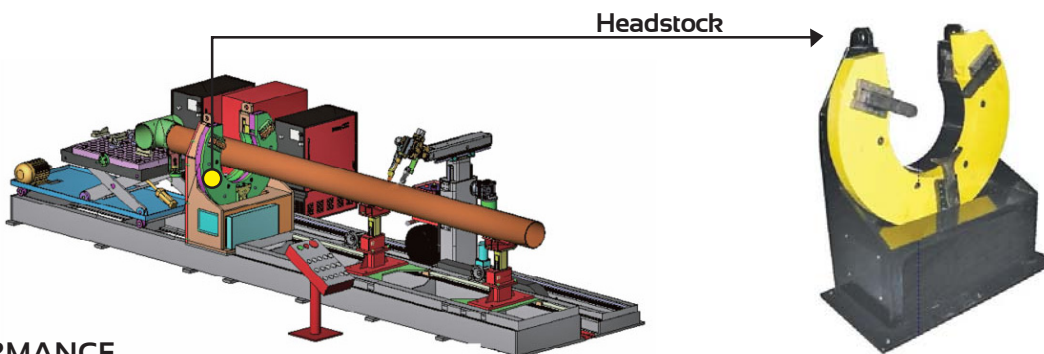

PERFORMANCE

- Unique open design convenient for large production areas
- Motorized three-jaw chuck positioning system to automatically center tube or pipe
- Anti-spatter headstock design
- Commonly used with MIG/MAG welding
- Can be used with MIG or TIG root welding, may also be used with PAW, SAW and other welding processes
- Designed for easy loading of large components
- Suitable for shipbuilding, chemical, nuclear plants and other prefab industries

PH-O Series	PH-O-4	PH-O-9	PH-O-14	PH-O-30
Diameter Range mm (inches)	19-114mm (.75"-4.5")	34-230mm (1.34"-9.05")	114-370mm (4.5"-14.6")	219-760mm (8.6"-30")
Loading Capacity (kg)	200	550	1300	15000
Loading Capacity (lbs)	440lbs	250lbs	2860lbs	6820lbs
Welding Speed (rpm)	5.3	3	4.3	0.669
Max. Torque (N m)	125	1037	2500	30000
Max. Torque (lbf ft)	92	765	1844	22127
Power (kw)	0.07	0.4	1.3	4
Power	0.09	0.54	1.74	5.36
Center Height (mm)	375	570	670	1405
Center Height (inches)	14.75"	22.5"	26.5"	55.5"
Dimension (mm)	300 x 252 x 475	520 x 390 x 795	924 x 460 x 1024	115 x 1285 x 2090
Dimension (inches)	12" x 10" x 19"	20.5" x 15.5" x 31.5"	36.5" x 18" x 40.5"	4.5" x 51" x 83"

TPF-WS SYSTEM (Flange Welding System for Tube and Pipe)

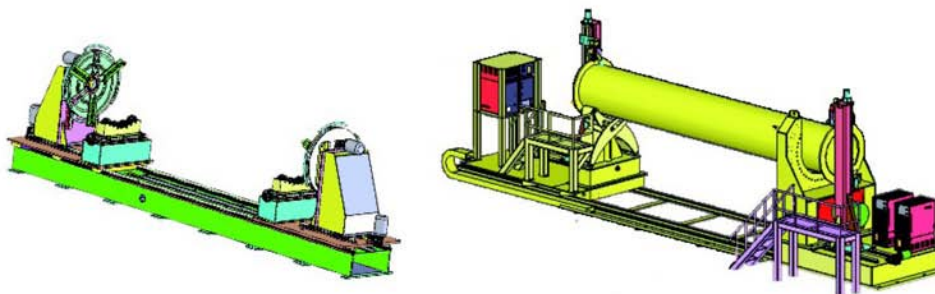

PERFORMANCE

- Commonly used for ship tube and flange welding
- Automatic self-checking tube and flange assembly
- Up to four torches for simultaneous or separate tube/flange welds
- Reliable mechanism structure designed to minimize tube/flange deviation
- Suitable for shipbuilding, chemical, nuclear plants and other prefab industries

TPF-WS System		
Wall Thickness mm (inches)	Tube: 3.5 - 28mm Flange: 5 - 80mm	Tube: .138" - 1.1" Flange: .196 - 3.15"
Workpiece OD Size and Length mm (inches)	48-219, 1000-6000mm 60- 480, 1000-9000mm 219-914, 1000-12000mm	(1.890"-8.62", 40"-236") (2.36"-18.9", 40"-354") (8.62"-36", 40"-472")
Max. Capacity Diameter mm (inches) and kg (lbs)	48-168mm, 1000kg 60-480mm, 3000kg 219-914mm, 5000kg	1.89"-6.61", 2200lbs 2.36"-18.9", 6600lbs 8.62"-36", 11000lbs

TUNGSTEN TIPS FOR TPWH CLOSED HEADS

RECOMMENDED TUNGSTEN GEOMETRY

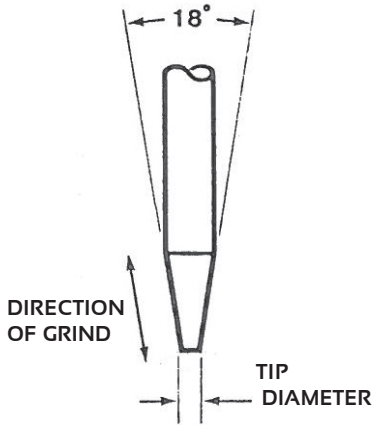

Item	Item ID	OD Size (Inches)	Arc Gap (Inches)	Wall Thickness (Inches)
TPWH-C-5				
TPWH-C-5	TC04-0915-02	0.125	0.03	0.035
TPWH-C-5	TC04-0852-02	0.25	0.03	0.035
TPWH-C-5	TC04-0790-02	0.375	0.03	0.035
TPWH-C-5	TC04-0708-02	0.5	0.5	0.049
TPWH-C-1				
TPWH-C-1	TC06-1006-02	0.125	0.03	0.035
TPWH-C-1	TC06-1045-02	0.25	0.03	0.035
TPWH-C-1	TC06-0983-02	0.375	0.03	0.035
TPWH-C-1	TC06-0920-03	0.5	0.03	0.049
TPWH-C-1	TC06-0832-03	0.625	0.05	0.065
TPWH-C-1	TC06-0795-03	0.75	0.05	0.065
TPWH-C-1	TC06-0670-03	1	0.05	0.065
TPWH-C-1.5				
TPWH-C-1.5	TC06-1245-02	0.25	0.03	0.035
TPWH-C-1.5	TC06-1983-02	0.375	0.03	0.035
TPWH-C-1.5	TC06-1120-03	0.5	0.05	0.049
TPWH-C-1.5	TC06-1058-03	0.625	0.05	0.065
TPWH-C-1.5	TC06-0995-03	0.75	0.05	0.065
TPWH-C-1.5	TC06-0870-03	1	0.05	0.065
TPWH-C-1.5	TC06-0620-03	1.5	0.05	0.065
TPWH-C-3				
TPWH-C-3.0	TC06-1985-03	0.75	0.05	0.065
TPWH-C-3.0	TC06-1860-03	1	0.05	0.065
TPWH-C-3.0	TC06-1610-03	1.5	0.05	0.065
TPWH-C-3.0	TC06-1350-03	2	0.05	0.065
TPWH-C-3.0	TC06-1110-03	2.5	0.05	0.065
TPWH-C-3.0	TC06-0910-03	3	0.05	0.065
TPWH-C-4				
TPWH-C-4	TC09-2548-04	1.315	0.07	0.109
TPWH-C-4	TC06-2475-03	1.5	0.05	0.065
TPWH-C-4	TC09-2475-03	1.5	0.05	0.065
TPWH-C-4	TC09-2255-04	1.9	0.07	0.109
TPWH-C-4	TC06-2225-03	2	0.05	0.065
TPWH-C-4	TC09-2225-03	2	0.05	0.065
TPWH-C-4	TC09-2018-04	2.375	0.07	0.109
TPWH-C-4	TC06-1975-03	2.5	0.05	0.065
TPWH-C-4	TC09-1975-03	2.5	0.05	0.065
TPWH-C-4	TC06-1725-03	3	0.05	0.065
TPWH-C-4	TC09-1725-03	3	0.05	0.065
TPWH-C-4	TC09-1455-04	3.5	0.07	0.109
TPWH-C-4	TC06-1205-03	4	0.07	0.083
TPWH-C-4	TC09-1205-03	4	0.07	0.083
TPWH-C-4	TC09-0955-04	4.5	0.07	0.12
TPWH-C-6				
TPWH-C-6	TC06-3410-03	2	0.05	0.065
TPWH-C-6	TC09-3023-04	2.375	0.07	0.109
TPWH-C-6	TC06-3160-03	2.5	0.05	0.065
TPWH-C-6	TC06-2910-03	3	0.05	0.065
TPWH-C-6	TC09-2640-04	3.5	0.07	0.109
TPWH-C-6	TC06-2390-03	4	0.07	0.083
TPWH-C-6	TC09-2140-04	4.5	0.07	0.12
TPWH-C-6	TC09-1890-04	5	0.07	0.83
TPWH-C-6	TC09-1609-04	5.563	0.07	0.134
TPWH-C-6	TC09-1390-04	6	0.07	0.109



SPRING BALANCER

The spring balancer is specially designed for tube to tube weld heads. It helps assist with controlling the weld head based on positioning by balance. This accessory helps make the process of locating the center of the tube quick and easy as well as keeping the weld head stable.

PERFORMANCE

- Convenient for moving
- Adjustable weight loading range
- For tube to tube sheet weld heads

SPRING BALANCER (SB-1)

Loading (kg/lbs)	9-15kg (19-33lbs.)
Traverse (mm/inches)	2000mm (78")
Weight (kg/lbs)	3.8kg (8lbs.)

MANIPULATOR

The manipulator is also designed for tube to tube sheet welding. The manipulator allows the operation to be easy and convenient by controlling the position of the weld head by 3 moving axes and by using pneumatic locking. It also assists with locating the center of the tube and creates stability during the welding process.

PERFORMANCE

- Durable and stable steel construction
- Linear track for each axis for smooth and reliable operation
- Three-axes pneumatic locking system
- Two fixed and flexible wheels, easy to move
- For tube to tube sheet weld heads
- Patented design

MANIPULATOR (TPF-M)

	Milimeters	Inches
Height Between Tube and Ground	600mm	23.5"
X axis Traverse	1500mm	59"
Y-axis Traverse	1000mm	39.5"
Z-axis Traverse	450mm	17.5"
Weight	230kg	507 lbs
Dimensions	2080 x 1010 x 1850mm	81"x39.5"x72"



EXTERNAL / INTEGRATED WIRE FEEDER

PERFORMANCE

- Simple design
- Light weight, easy to carry
- Branded Servo motor driving system
- Loop control
- Stable wire feeding speed
- Compatible with all TPWH-O and TPWH-OA Series weld heads



WIRE FEEDERS	EXTERNAL WIRE FEEDER (WFE-1)	INTEGRATED WIRE FEEDER (WFI-1)
Wire Feeding Speed (mm/inches)	100-1800 mm/min (4"-70")	100-1800 mm/min (4"-70")
Wire Diameter (mm/inches)	1.0mm (0.039")	0.8mm, 0.9mm, 1.0mm
Weight (kg/lbs)	7.34kg (16lbs)	1.5kg (3lbs.)

*Cable Length 4mm (1/2")



BEVELING

BEVELING

BEVELING

BEVELING

BEVELING

BEVELING

BEVELING

BEVELING

BEVELING

BEVELING

BEVELING

BE

BEVELING

BEVELING

BEVELING

BEVELING

BEVELING

BEVELING

BEVELING PRODUCTS

PBM-2500 • 1" to 2.5" PIPE (ID MOUNT / AIR OR ELECTRIC)

WITH OPTIONAL SIZE RANGE OF 0.5" TO 2.5"

FEATURES

The PBM-2500 machine is light weight, just 13 lbs. and is designed to bevel boiler tubes. Our heavy duty tool bits are held in by our wedge lock system.

The torque accepting mandrel with lock in blades (no springs) easily stops any pieces from dropping down into the boiler tube. Our gear drive unit has spiral bevel gears for better torque (more teeth engagement, compared to standard straight gears that other competitors use).

PBM-2500 Air Motor



TB-1123

TB-1124



PBM-2500 Electric Motor

PBM-2500 Machine Kit Includes: Machine, Tool Bits (2), Tooling, Manual and Case

PBM-2500 Kit with Electric 110v Motor	P/N: PBM-2500-IO-E
PBM-2500 Kit with Electric 230v Motor	P/N: PBM-2500-IO-E-230
PBM-2500 Kit with Air Motor	P/N: PBM-2500-IO

PERFORMANCE

- Size range for Pipe 1" to 2.5" (12.7 mm - 63.5 mm)
- Max wall thickness to 0.50"
- Air Power requirements: 40 cfm at 90 psi.
- Lock in mandrel blades (no springs to lose)
Adjustable keyway on machine and mandrel (eliminates backlash and chatter)
- .75 hp pneumatic motor
- 13 lbs. approximate working weight
Hardened mandrel 55 Rc.
(less chance of gouging with metal chips)
- Tool bit is held in by our wedge lock system
(keeps the tool bit locked in the cutter head to ensure chatter free bevels)
- Single mandrel with mandrel blades to cover size ranges

TOOL BITS FOR PBM-2500

TB-1122	37.5 degree heavy duty bevel bit (upper range)
TB-6964	37.5 degree bevel bit (lower range, extended)
* TB-1123	.950 Facing bit
* TB-1124	37.5 degree bevel bit (extended)
TB-1125	30 degree heavy duty bevel bit
TB-1127	30 degree standard bevel bit
TB-1128	25 degree "J" bevel bit (upper range)
TB-1128L	25 degree "J" bevel bit (lower range)
TB-6963	Facing bit (1" extended reach)
TB-6965	30 degree bevel bit (lower range, extended)

* *Tool bits included in kit*

PBM-2500 ACCESSORIES

Optional Mandrel 0.5" to 1.25" OD	P/N: PBM-2590
Air Caddy - Includes air regulator, filter and oil mister	P/N: PBM-AF

All beveling machines come packaged in our heavy duty case with tooling, tool bits(2), manual and required ramps.



FEATURES - BUILT WITH A WORM GEAR DRIVE UNIT FOR EXTRA TORQUE!

The PBM-4500 machine comes with a torque accepting mandrel, built with a worm gear drive unit for extra torque to handle extra thick pipe walls. This machine can bevel, face, and counter-bore.



PBM-4500 Machine Kit Includes: Machine, Tool Bits (2), Tooling, Manual and Case

PBM-4500 Kit with Electric 110v Motor	P/N: PBM-4500-10-E
PBM-4500 Kit with Electric 230v Motor	P/N: PBM-4500-10-E-230
PBM-4500 Kit with Air Motor	P/N: PBM-4500-10

PERFORMANCE

- Size range 1.25" to 4.5" Pipe (31.74 mm -101.6 mm)
- Max wall thickness to 1"
- Air Power requirements: 76 cfm at 90 psi.
- Lock in mandrel blades (no springs to lose)
- Adjustable keyway on machine and mandrel (eliminates backlash and chatter)
- 1.5 HP pneumatic motor
- 31 lbs. approximate working weight
- Hardened mandrel 55 Rc. (less chance of gouging with metal chips)
- Three slots to do beveling, facing, deburring or counter-boring
- Single mandrel with mandrel blades to cover various size ranges

Many tool bit sizes available, contact us for further details.

TOOL BITS FOR PBM-4500

TB-0167	37.5 degree bevel bit (lower range)
TB-0168	4 degree chamfer/deburr bit
TB-0169	Facing bit (.75" Height)
* TB-0257	Facing bit (.875" Height)
TB-0258	Facing bit (1" Height)
* TB-0333	37.5 degree bevel bit 2" to 3.5" pipe
TB-0333-1	37.5 degree heavy bevel bit 2" to 3.5" pipe
TB-0944	37.5 degree bevel bit (upper range)
TB-1273	45 degree bevel bit (lower range)
TB-1274	45 degree bevel bit (upper range)
TB-2566	25 degree "J" bevel bit (lower range)
TB-2567	25 degree "J" bevel bit (upper range)
TB-2568	20 degree "J" bevel bit (lower range)
TB-2569	20 degree "J" bevel bit (upper range)
TB-3030	30 degree bevel bit (lower range)
TB-3035	30 degree bevel bit (upper range)
TB-412-01	10 degree counterbore bit (lower range)
TB-412-02	10 degree counterbore bit (upper range)
* Tool bits included in kit	

PBM-4500 ACCESSORIES

MANDREL OPTIONS FOR PBM-4500

.625" to 1.25" Mandrel	P/N: PBM-4590
1.25" to 4" Standard Mandrel	P/N: PBM-0490
2" to 6" Mandrel	P/N: PBM-0491
2" to 6" Extension Mandrel Kit	P/N: PBM-4500-EXT

ELBOW MANDREL FOR PBM-4500

Range 2"- 2.5"	P/N: EB-4500-2
Range 2.5"- 3"	P/N: EB-4500-2.5
Range 3"- 4"	P/N: EB-4500-3
Range 4"- 5"	P/N: EB-4500-4
Range 5"- 6"	P/N: EB-4500-5
Range 6"- 7"	P/N: EB-4500-6



AIR CADDY	PART NUMBER
Recommended for air motors	P/N: PBM-AF

BEVELING PRODUCTS

PBM-6000 • 2" to 6" PIPE (ID MOUNT / AIR OR ELECTRIC)

WITH OPTIONAL SIZE RANGE OF 2" TO 8"

FEATURES

The PBM-6000 machine comes with a torque accepting mandrel, built with a worm gear drive unit for extra torque to handle extra thick pipe walls. This machine can bevel, face, and counter-bore 1.25" wall - worry free from damaging the gears.

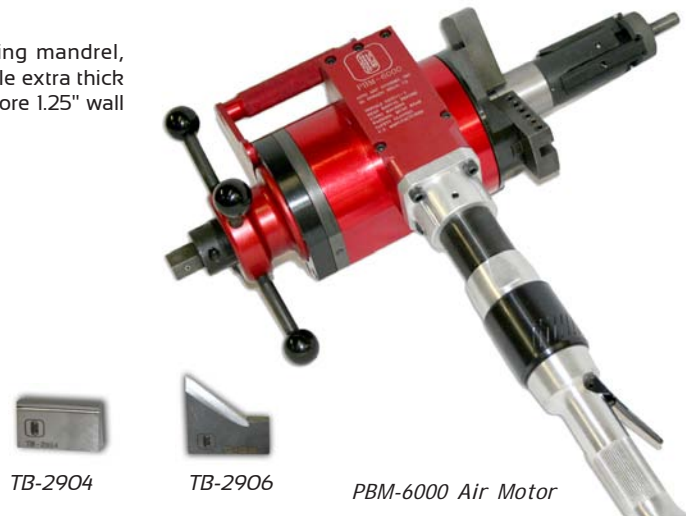

PBM-6000 Machine Kit Includes: Machine, Tool Bits (2), Tooling, Manual and Case

PBM-6000 Kit with Electric 110v Motor	P/N: PBM-6000-10-E
PBM-6000 Kit with Electric 230v Motor	P/N: PBM-6000-10-E-230
PBM-6000 Kit with Air Motor	P/N: PBM-6000-10

PERFORMANCE

- Size range 2" to 6" Pipe (50.8 mm - 152.4 mm)
- Max wall thickness to 1.25"
- Air Power requirements: 76 cfm at 90 psi.
- Lock in mandrel blades (no springs to lose)
- Adjustable keyway on machine and mandrel (eliminates backlash and chatter)
- 2 hp pneumatic motor
- 52 lbs. approximate working weight
- Hardened mandrel 45 Rc. (less chance of gouging with metal chips)
- Three slots to do beveling, facing, deburring or counter-boring
- Single mandrel with mandrel blades to cover size ranges

Many tool bit sizes available, contact us for further details.

TOOL BITS FOR PBM-6000

TB-2902	Facing Bit (1" Height)
TB-2903	Facing Bit (.875" Height)
* TB-2904	Facing Bit (.75" Height)
TB-2905	37.5 degree bevel bit (lower range)
* TB-2906	37.5 degree bevel bit (upper range)
TB-2907	C-Bore 14.5 degree (lower range)
TB-2908	C-Bore 14.5 degree (middle range)
TB-2909	C-Bore 14.5 degree (upper range)
TB-2910	C-Bore 10 degree (lower range)
TB-2911	C-Bore 10 degree (middle range)
TB-2912	C-Bore 10 degree (upper range)
TB-2913	45 degree bevel bit (lower range)
TB-2914	45 degree bevel bit (upper range)
TB-8997	20 degree "J" bevel bit (lower range)
TB-8998	20 degree "J" bevel bit (upper range)
TB-2915	25 degree "J" bevel bit (lower range)
TB-2916	25 degree "J" bevel bit (upper range)
TB-2930	30 degree bevel bit (lower range)
TB-2931	30 degree bevel bit (upper range)

* **Tool bits included in kit**

PBM-6000 ACCESSORIES

2" to 6" Standard Mandrel	P/N: PBM-8920
3" to 8" Extension Mandrel Kit	P/N: PBM-8925
3" to 8" Mandrel	P/N: PBM-8912
Air Caddy - Includes air regulator, filter and oil mister	P/N: PBM-AF

FEATURES

The PBM-8000 machine comes with a torque accepting mandrel, built with a worm gear drive unit for extra torque to handle extra thick pipe walls. This machine can bevel, face and counter-bore 1.25" wall.



PBM-8000 Machine Kit Includes: Machine, Tool Bits (2), Tooling, Manual and Case

PBM-8000 Kit with Electric 110v Motor	P/N: PBM-8000-10-E
PBM-8000 Kit with Electric 230v Motor	P/N: PBM-8000-10-E-230
PBM-8000 Kit with Air Motor	P/N: PBM-8000-10

PERFORMANCE

- Size range 3" to 8" Pipe (76.2 mm - 203.2mm)
- Max wall thickness to 1.25"
- Air Power requirements: 76 cfm at 90 psi.
- Additional 10" extension kit
- Lock in mandrel blades (no springs to lose)
- Adjustable keyway on machine and mandrel (eliminates backlash and chatter)
- 2.5 HP pneumatic motor
- 66 lbs. approximate working weight
- Hardened mandrel 45 Rc. (less chance of gouging with metal chips)
- Three slots to do beveling, facing, deburring or counter-boring
- Single mandrel with mandrel blades to cover size ranges

Many tool bit sizes available, contact us for further details.

TOOL BITS FOR PBM-8000

TB-2902	Facing Bit (1" Height)
TB-2903	Facing Bit (.875" Height)
* TB-2904	Facing Bit (.75" Height)
TB-2905	37.5 degree bevel bit (lower range)
* TB-2906	37.5 degree bevel bit (upper range)
TB-2907	C-Bore 14.5 degree (lower range)
TB-2908	C-Bore 14.5 degree (middle range)
TB-2909	C-Bore 14.5 degree (upper range)
TB-2910	C-Bore 10 degree (lower range)
TB-2911	C-Bore 10 degree (middle range)
TB-2912	C-Bore 10 degree (upper range)
TB-2913	45 degree bevel bit (lower range)
TB-2914	45 degree bevel bit (upper range)
TB-8997	20 degree "J" bevel bit (lower range)
TB-8998	20 degree "J" bevel bit (upper range)
TB-2915	25 degree "J" bevel bit (lower range)
TB-2916	25 degree "J" bevel bit (upper range)
TB-2930	30 degree bevel bit (lower range)
TB-2931	30 degree bevel bit (upper range)

* **Tool bits included in kit**

PBM-8000 ACCESSORIES

2" to 6" Mandrel	P/N: PBM-8920
3" to 8" Standard Mandrel	P/N: PBM-8912
6" to 10" Mandrel	P/N: PBM-1202
10" Extension Mandrel Kit	P/N: PBM-8000-EXT
Air Caddy - Includes air regulator, filter and oil mister	P/N: PBM-AF

BEVELING PRODUCTS

PBM-614 • 6" to 14" PIPE (ID MOUNT / AIR OR ELECTRIC)

WITH OPTIONAL SIZE RANGE OF 3" TO 14"

FEATURES

The PBM-614 machine comes with a torque accepting mandrel, built with a worm gear drive unit for extra torque to handle extra thick pipe walls. This machine can bevel, face, and counter-bore 1.25" wall.



PBM-614 Electric Motor



TB-2904



TB-2906

PBM-614 Machine Kit Includes: Machine, Tool Bits (2), Tooling, Manual and Case

PBM-614 Kit with Electric 110v Motor	P/N: PBM-14-10-E
PBM-614 Kit with Electric 230v Motor	P/N: PBM-14-10-E-230
PBM-614 Kit with Air Motor	P/N: PBM-14-10

PERFORMANCE

- Size range 6" to 14" Pipe (152.4 mm - 355.6mm)
- Max wall thickness to 1.25"
- Air Power requirements: 76 cfm at 90psi
- Lock in mandrel blades (no springs to lose)
- Adjustable keyway on machine and mandrel (eliminates backlash and chatter)
- 3hp pneumatic motor
- 94 lbs. approximate working weight
- Hardened mandrel 55 Rc. (less chance of gouging with metal chips)
- Three slots to do beveling, facing, deburring or counter-boring
- Single mandrel with mandrel blades to cover size ranges
- One cutter slot for heavy duty tool bits

Many tool bit sizes available, contact us for further details.

TOOL BITS FOR PBM-12000

TB-2902	Facing Bit (1" Height)
TB-2903	Facing Bit (.875" Height)
* TB-2904	Facing bit (.750" Height)
TB-2905	37.5 degree bevel bit (lower range)
* TB-2906	37.5 degree bevel bit (upper range)
TB-2907	C-Bore 14.5 degree (lower range)
TB-2908	C-Bore 14.5 degree (middle range)
TB-2909	C-Bore 14.5 degree (upper range)
TB-2910	C-Bore 10 degree (lower range)
TB-2911	C-Bore 10 degree (middle range)
TB-2912	C-Bore 10 degree (upper range)
TB-2913	45 degree bevel bit (lower range)
TB-2914	45 degree bevel bit (upper range)
TB-8997	20 degree "J" bevel bit (lower range)
TB-8998	20 degree "J" bevel bit (upper range)
TB-2915	25 degree "J" bevel bit (lower range)
TB-2916	25 degree "J" bevel bit (upper range)
TB-2930	30 degree bevel bit (lower range)
TB-2931	30 degree bevel bit (upper range)
Heavy Duty Tool Bits (For wall thickness 5/8" and over)	
TB-2924	37.5 degree bevel bit
TB-2925	37.5 / 10 degree compound bevel bit
TB-2926	30 degree bevel bit
TB-2927	20 degree J-Bevel
TB-2928	25 degree J-Bevel

* Tool bits included in kit

PBM-614 ACCESSORIES

3" to 8" Mandrel	P/N: PBM-6501
6" to 14" Standard Mandrel	P/N: PBM-6502
Air Caddy - Includes air regulator, filter and oil mister	P/N: PBM-AF

FEATURES

The PBM-1224 machine comes with a torque accepting mandrel, built with a worm gear drive unit for extra torque to handle extra thick pipe walls. This machine can bevel, face, and counter-bore 1.25" wall.



TB-2904



TB-2906

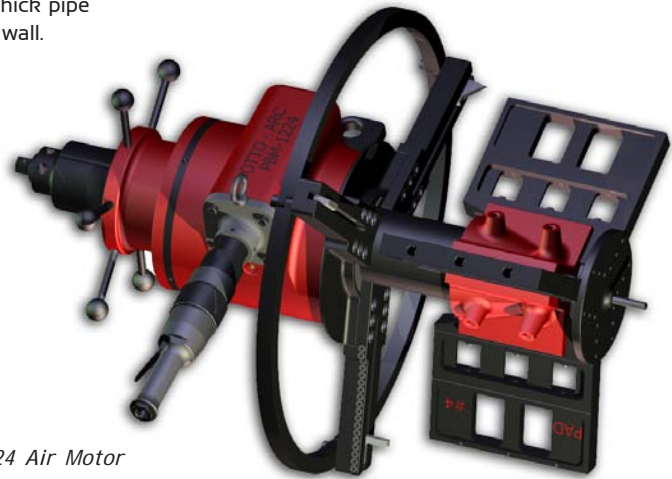

PBM-1224 Air Motor

PBM-1224 Machine Kit Includes: Machine, Tool Bits (2), Tooling, Manual and Case

PBM-1224 Kit with Electric 110v Motor	P/N: PBM-24-10-E
PBM-1224 Kit with Electric 230v Motor	P/N: PBM-24-10-E-230
PBM-1224 Kit with Air Motor	P/N: PBM-24-10

PERFORMANCE

- Size range 12" to 24" Pipe (152.4 mm - 609.6mm)
- Max wall thickness to 1.25"
- Air Power requirements: 76 cfm at 90psi
- Lock in mandrel blades (no springs to lose)
- Adjustable keyway on machine and mandrel (eliminates backlash and chatter)
- 3hp pneumatic motor
- 260 lbs. approximate working weight
- Hardened mandrel 55 Rc. (less chance of gouging with metal chips)
- Three slots to do beveling, facing, deburring or counter-boring
- Single mandrel with mandrel blades to cover size ranges
- One cutter slot for heavy duty tool bits

Many tool bit sizes available, contact us for further details.

TOOL BITS FOR PBM-1224

TB-2902	Facing Bit (1" Height)
TB-2903	Facing Bit (.875" Height)
* TB-2904	Facing bit (.750 Height)
TB-2905	37.5 degree bevel bit (lower range)
* TB-2906	37.5 degree bevel bit (upper range)
TB-2907	C-Bore 14.5 degree (lower range)
TB-2908	C-Bore 14.5 degree (middle range)
TB-2909	C-Bore 14.5 degree (upper range)
TB-2910	C-Bore 10 degree (lower range)
TB-2911	C-Bore 10 degree (middle range)
TB-2912	C-Bore 10 degree (upper range)
TB-2913	45 degree bevel bit (lower range)
TB-2914	45 degree bevel bit (upper range)
TB-8997	20 degree "J" bevel bit (lower range)
TB-8998	20 degree "J" bevel bit (upper range)
TB-2915	25 degree "J" bevel bit (lower range)
TB-2916	25 degree "J" bevel bit (upper range)
TB-2930	30 degree bevel bit (lower range)
TB-2931	30 degree bevel bit (upper range)
Heavy Duty Tool Bits (For wall thickness 5/8" and over)	
TB-2924	37.5 degree bevel bit
TB-2925	37.5 / 10 degree compound bevel bit
TB-2926	30 degree bevel bit
TB-2927	20 degree J-Bevel
TB-2928	25 degree J-Bevel

* Tool bits included in kit

PBM-1224 ACCESSORIES

Air Caddy - Includes air regulator, filter and oil mister	P/N: PBM-AF
---	-------------

BEVELING PRODUCTS

SP 6-30 SPLIT FRAME • 2" to 30" (OD MOUNT / AIR OR ELECTRIC)

FEATURES

Our precision OD Mount Machines are designed to operate in tight areas. This machine can do both cut-off and end prep at the same time. We offer tool bits for standard and compound beveling to fit your requirements.

Beveling is done by cold cutting methods and can be used in areas where thermal cutting is unacceptable. These machines will produce machine type finishes without causing heat affected zones. Our line of split frame machines are easy to set up with self-centering mounting pads, saving time on labor.

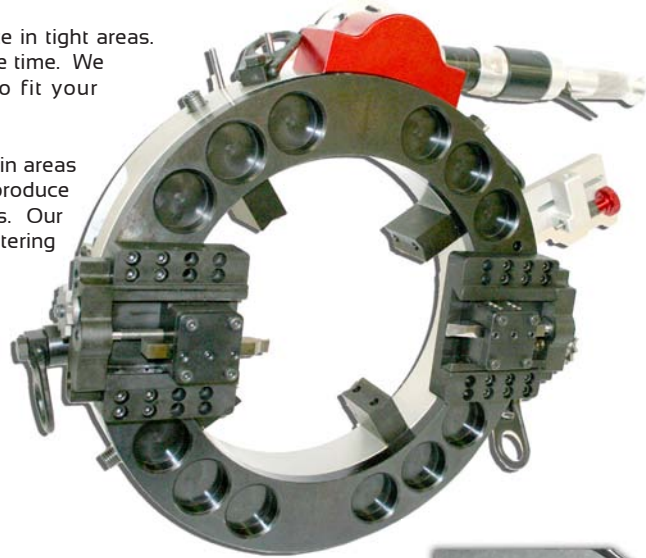

SP24 with Air Motor



TB-6953

TB-6958

PERFORMANCE

- High performance electric motor allows the required torque to bevel from 2" to 30" pipe
- The motor contains specially designed reduction gears that help increase the torque while reducing the speed of the electric motor
- Various RPM rates are available to meet different range requirements
- Optional counterbore attachment available

TOOL BITS FOR SP 6-30

TB-6950	30 degree double bevel bit
TB-6952	30 degree right hand bevel bit
TB-6954	30 degree left hand bevel bit
TB-6951	37.5 degree double bevel bit
* TB-6953	37.5 degree right hand bevel bit
TB-6955	37.5 degree left hand bevel bit
TB-6957	Sever bit (left hand)
* TB-6958	Sever bit (right hand)
TB-6959	Sever double bevel bit
TB-6969	25 degree "J" bevel
TB-6956	10/30 degree compound bevel bit
* <i>Tool bits included in kit</i>	

SP 6-30 Machine Kit Includes: Machine, Tool Bits (2), Tooling, Manual and Case

ELECTRIC (110v or 230v Motor)

SP6 Kit (2" - 6")	P/N: SP6-10-E
SP12 Kit (6" - 12")	P/N: SP12-10-E
SP18 Kit (12" - 18")	P/N: SP18-10-E
SP24 Kit (18" - 24")	P/N: SP24-10-E
SP30 Kit (24" - 30")	P/N: SP30-10-E

AIR

SP6 Kit (2" - 6")	P/N: SP6-10
SP12 Kit (6" - 12")	P/N: SP12-10
SP18 Kit (12" - 18")	P/N: SP18-10
SP24 Kit (18" - 24")	P/N: SP24-10
SP30 Kit (24" - 30")	P/N: SP30-10
Air Caddy - includes air regulator, filter and oil mister	P/N: PBM-AF

Note: for 230v motor please add 230 on to part number (ex: SP3-10-E-230)

SP 24-48 SPLIT FRAME • 18" to 48" (OD MOUNT / HYDRAULIC OR SERVO)

FEATURES

OD MOUNT / HYDRAULIC OR NC SERVO MOTOR



SP48-NC



Hydraulic Motor Drive

Options:

- Tank heaters for hydraulic oil
- Control panel for heaters
- Pendant cable with lengths up to 150 feet
- Custom hydraulic hoses for specific applications
- Hose and fittings to match system connectors



Servo Motor Drive



TB-6953



TB-6958

TECHNICAL SPECS FOR HYDRAULIC MOTOR

10 HP Hydraulic Motor (approx.)

Weight 605lbs. with oil and mobile base
 Current draw 20Amps (Rec. 30Amp Breaker)
 Oil capacity 15 gal. AW 32 or 46
 Hydraulic pressure factory set at 1800psi
 Hydraulic flow 3 to 9 GPM
 Dim. with mobile base: 46" x 20.5" x 28"

20 HP Hydraulic Motor (approx.)

Weight 850lbs. with oil and mobile base
 Current draw 30Amps (Rec. 50Amp Breaker)
 Oil capacity 30 gal. AW 32 or 46
 Hydraulic pressure factory set at 1800psi
 Hydraulic flow 3 to 18 GPM
 Dim. with mobile base: 46" x 23.5" x 32"

TOOL BITS FOR SP 24-48

- TB-6950 30 degree double bevel bit
- TB-6952 30 degree right hand bevel bit
- TB-6954 30 degree left hand bevel bit
- TB-6951 37.5 degree double bevel bit
- * TB-6953 37.5 degree right hand bevel bit
- TB-6955 37.5 degree left hand bevel bit
- TB-6957 Sever bit (left hand)
- * TB-6958 Sever bit (right hand)
- TB-6959 Sever double bevel bit
- TB-6969 25 degree "J" bevel
- TB-6956 10/30 degree compound bevel bit

* Tool bits included in kit

Optional counterbore attachment available

TECHNICAL SPECS FOR NC SERVO MOTOR

Power Supply: 220v, 380v, or 440v
 Rated Power: N=1-2.5KW
 Rated Frequency: F=50-60Hz
 Timing Range: 0-30r/min

SP 24-48 Machine Kit Includes: Machine, Tool Bits (2), Tooling, Manual and Case

SP 24-48

SP24 Kit (18" - 24")	P/N: SP24-H
SP30 Kit (24" - 30")	P/N: SP30-H
SP36 Kit (30" - 36")	P/N: SP36-H
SP42 Kit (36" - 42")	P/N: SP42-H
SP48 Kit (42" - 48")	P/N: SP48-H

NC SERVO MOTOR

SP24 Kit (18" - 24")	P/N: SP24-NC
SP30 Kit (24" - 30")	P/N: SP30-NC
SP36 Kit (30" - 36")	P/N: SP36-NC
SP42 Kit (36" - 42")	P/N: SP42-NC
SP48 Kit (42" - 48")	P/N: SP48-NC
NC Servo Power Supply Unit with Remote Control	P/N: SERVO-100

HYDRAULIC POWER SOURCE / MOTOR

P/N: HYD-10 (Power Source)
P/N: HYD-20 (Power Source)
P/N: HYD-M (Hydraulic Motor Drive Unit)

QUICK CUT SAW

FOR STAINLESS AND CARBON STEEL PIPES/TUBING

ELECTRIC

Designed to perform true and burr free cuts with our specially designed vice that creates a self-centering hold for the finest cuts. Ideal for high-purity applications!

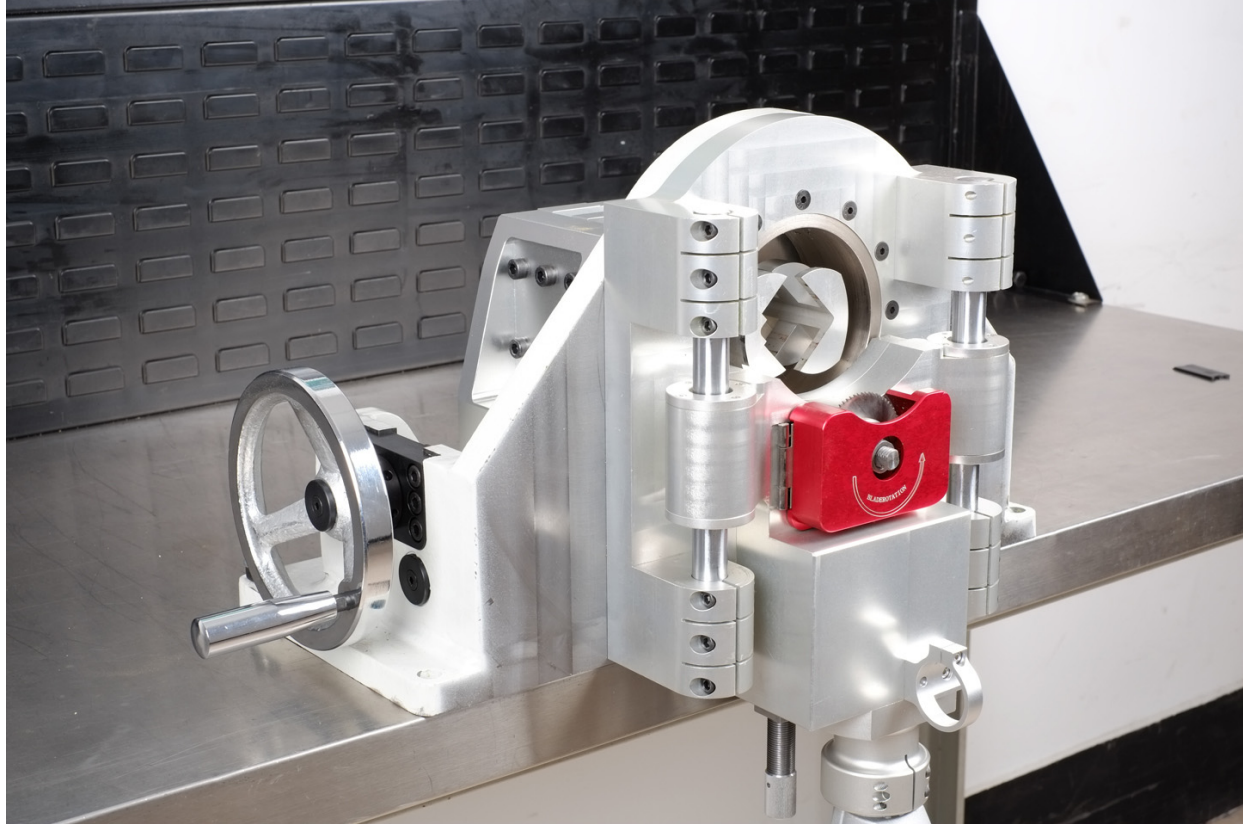

Our Otto Arc "Quick Cut Saw" is designed for fabrication facilities and for projects that require beveling or squaring for pre-prep welding of pipes and tubes.

PERFORMANCE

- Will cut tubing from .75" to 4.5"
- Will cut piping from 1" to 4"
- Will cut square to .005"
- Steady rest for accurate cutting
- Enclosed gear box (does not require expensive oil)
- Enclosed bearings for smooth operation
- Designed to keep out chips during operation
- Simple to adjust sizes and depth
- Performs bevels and squaring
- Ideal for high-purity applications
- Can also cut plastic, aluminum and a variety of other alloys
- Electric motor: variable speed control 110v or 220v

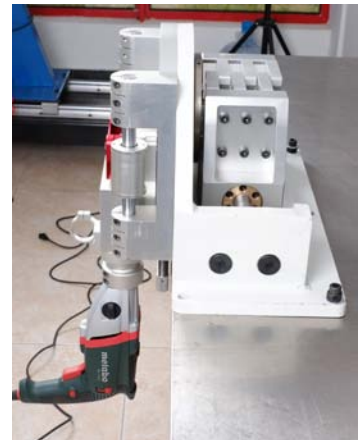

QC-4000 Side View

QUICK CUT SAW	MOTOR SPECS	WEIGHT
PN: QC-4000-E (electric)	110V/60Hz or 220V/50Hz	60kg (132lbs.)
BEVELING BLADES		
	30 DEGREE BEVEL	37.5 DEGREE BEVEL
PN: QC-B-30	QC-B-37.5	

FOR HEAVY DUTY CUTTING (4" to 30" OD pipe)

**ON-SITE CUTTING FOR PIPE UP TO 30" OD
PNEUMATIC • ELECTRIC • HYDRAULIC**

Designed for the toughest jobs - refineries, chemical plants, utilities, pipeline, construction, offshore oil and demolitions!



This line of power hacksaws offers a wide range of options for projects that require portable cutting of pipe, structural steel, tanks and other materials. Our saws are designed for the toughest industries such as, power plants, utilities, off shore oil, construction and demolition applications.

They are also designed to handle industry shut downs and turnarounds within the process piping industries. Another benefit when using this line of saws is the pneumatic option which contributes largely to safety. Using a pneumatic saw versus a welding torch to cut pipe will eliminate the risk of injury if your project is situated in a confined or hazardous area.

Pneumatic Hacksaw
Model: 5 1212 0010

Roll Throttle Option - only for auto feed clamp
Model: 5 1208 9980

Lever Throttle Option
Model: 5 1212 0050

Assorted pipe clamps for pipes up to 30" OD or profile clamps for structural steel. Manual or automatic feed option.

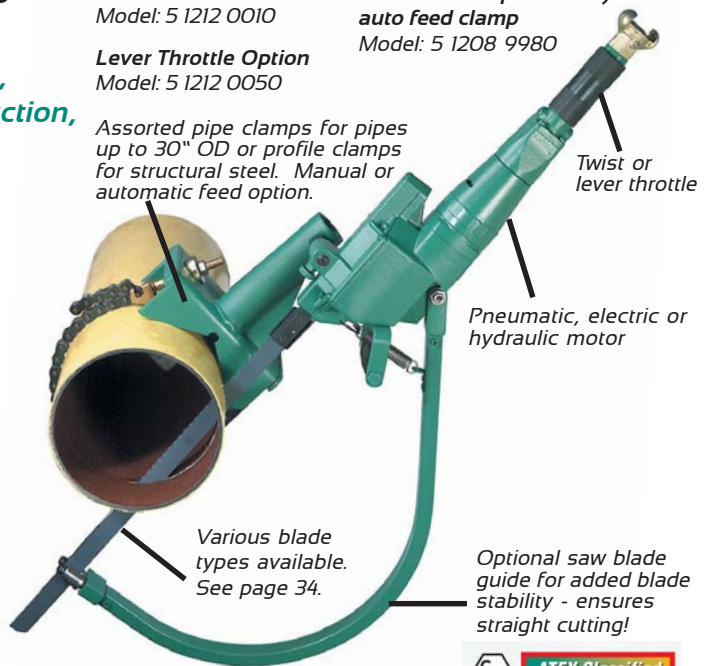

PERFORMANCE

- Compact size, ideal for cutting in confined spaces
- Profile clamps for structural steel
- Wide variety of blades and accessories for cutting steel, stainless steel, aluminum, plastic, wood and ductile iron
- Ideal for cutting pipe, tanks, structural steel etc.
- Pneumatic pipe clamp system available for automatically cutting pipe; easily attaches to pneumatic hacksaw, sharing same air supply
- Chain clamps and profile clamps available for accurate 90 degree cutting of pipe and structural steel
- Heavy-duty saw blades 8" to 37" long
- 2 3/8" blade stroke
- Variable speed motor
- Pipe capacity of 30" OD
- Profile capacity 21.75"H x11.5" W
- ATEX Classified: EX II 2 GcT5

*Note: carrying case not included with air models.
To order use PN: 5 1212 9000*

Electric Motor
Model: 5 1212 0070

Note: has an electronic speed dial control.



Also available in 220 Volt/50Hz

Hydraulic Motor
Model: 5 1220 0050



PNEUMATIC SAW (3/4" ID NPT AIR CONNECTION)	POWER	THROTTLE	MOTOR SPECS	STROKES PER MIN	BLADE STROKE	HOSE	WEIGHT
PN: 5 1212 0010	1.5 HP	Roll	Air Consumption: 51 CFM	100-350	2-3/8"	1/2" ID	15.4
PN: 5 1212 0050	1.5 HP	Lever	Air Pressure: 90 PSI	100-350	2-3/8"	1/2" ID	15.4
ELECTRIC SAW (11 AMPS/110 VOLT)	POWER	THROTTLE	MOTOR SPECS	STROKES PER MIN	BLADE STROKE	HOSE	WEIGHT
PN: 5 1215 0070	1.5 HP	Trigger	110V/60Hz or 220V/50Hz	200-400	2-3/8"	Cable	13
HYDRAULIC SAW (1/2" FF HTMA COUPLINGS)	POWER	THROTTLE	MOTOR SPECS	STROKES PER MIN	BLADE STROKE	HOSE	WEIGHT
PN: 5 1220 0050	3.8 HP	Lever	Oil Flow: 4 GPM at 2000 PSI	100-500	2-3/8"	1/2" ID	13.5

CLAMPS FOR PIPES AND PROFILES

Ensures 90° cuts through pipes and profiles

Profile Clamp

Model: 5 1207 8970



Large Clamp

Model: 5 1202 9960



Small Clamp

Model: 5 1207 9910



CLAMPS	DESCRIPTION
PN: 5 1202 9960 (large clamp)	4" TO 12-3/4" OD Pipe Clamp - manual tightening using open-end wrench
PN: 5 1202 9950 (large clamp)	4" TO 12-3/4" OD Pipe Clamp - tightens with built-in-rod
PN: 5 1207 9910 (small clamp)	2" TO 6" OD Pipe Clamp
PN: 5 1207 8970	21-5/8" x 11-3/8" Profile Clamp

Note: up to 24" OD requires one extension chain. Up to 30" OD requires two extension chains.

LEVER LOCK ASSEMBLY	DESCRIPTION
PN: 5 1202 9970	Can be used to retrofit manual clamp 5 1202 9960 for tightening versus using wrench. Also fits similar clamps.



AUTOMATIC SELF-FEEDING PIPE CLAMP FOR PNEUMATIC SAWS

- Save time and effort by automatically cutting pipe up to 12-3/4" OD (up to 30" OD with extension chain)
- Self-feeding device saves labor time, easy to use and increases safety
- Easily attaches to air hacksaw and shares same 90 PSI air supply (pipe clamp for use only with air hacksaw Model: 5 1212 0010)
- Optional blade guide for straight cutting through pipe and difficult material



Air Powered Clamp

SELF-FEEDING PIPE CLAMP FOR PNEUMATIC SAWS	DESCRIPTION
PN: 5 1208 9980	Automatic

AUTOMATIC SELF-FEEDING PIPE CLAMP FOR ELECTRIC/HYDRAULIC SAWS

- Save time and effort by automatically cutting pipe up to 12-3/4" OD (up to 30" OD with extension chain)
- Self-contained gas cylinder provides constant feed pressure to saw blade
- Self-feeding device saves operator time/increases safety
- Easily attaches to electric hacksaw 0070 or hydraulic hacksaw 0050
- Optional blade guide for straight cutting through pipe and difficult materials

Self Feeding Mechanical Clamp



SELF-FEEDING PIPE CLAMP FOR ELECTRIC AND HYDRAULIC SAWS	DESCRIPTION
PN: 5 1208 9990	Automatic

UNIVERSAL CLAMP

UNIVERSAL CLAMP	DESCRIPTION
PN: CPI	Self-aligning feet - adjusts to workpiece (round, square and angled). Accomodates 1/2" to 12-3/4" OD
PN: CPI/10	24" OD with extension chain (39-3/8" long)



EXTENSION CHAINS FOR PIPE CLAMPS

Extend capacity of pipe clamps up to 24"OD

EXTENSION CHAINS FOR PIPE CLAMPS	DESCRIPTION
PN: 5 1201 9010	17-3/4" Chain extension
PN: 5 1201 9030	39-3/8" Chain extension

Note: two of these chains allows pipe clamp 9950, 9960, 9980 and 9990 to fit 30" OD pipe.



BLADE GUIDES - OPTIONAL GUIDES WITH TWO ROLLER BEARINGS

Ensures straight cutting through pipe and difficult materials

BLADE GUIDES	DESCRIPTION
PN: 5 1207 9970	For pipes up to 13" (20" min. blade length required)
PN: 5 1207 8910	For pipes up to 21" (30" min. blade length required)



BLADE SIZES - HEAVY DUTY CUTTING OF PIPE AND STRUCTURAL STEEL

Let's you cut steel, stainless steel, aluminum and more!

PN:	LENGTH	TEETH / INCH	THICKNESS	MATERIAL TYPE	MAX. DIA. OF CUT
Z22-9 HSS	8"	8	1/16"	Steel/Aluminum	3-1/8"
Z22-10 HSS	8"	16	1/16"	Steel	3-1/8"
Z22-6 HSS-SL	12"	16	1/16"	Stainless Steel	6-5/8"
Z22-31 HSS	12"	12	1/16"	Steel	6-5/8"
Z22-29 HSS	16"	8	1/16"	Steel/Aluminum	10-5/8"
Z22-33 HSS	16"	6	1/16"	Steel	10-5/8"
Z22-72 HSS	20"	14	5/64"	Steel	14-5/8"
Z22-30 HSS	21"	12	1/16"	Steel	15-5/8"
Z22-30 HSS-SL	21"	12	1/16"	Stainless Steel	14-5/8"
Z22-73 HSS	24"	14	5/64"	Steel	18-1/2"
Z22-74 HSS	24"	8	5/64"	Steel/Aluminum	18-1/2"
Z22-75 HSS	30"	12	5/64"	Steel	24-7/8"
Z22-75 HSS-SL	30"	12	5/64"	Stainless Steel	24-7/8"
Z22-76 HSS	30"	6	5/64"	Heavy Wall Steel, Wood, Plastic	24-7/8"
Z22-37 HSS	37"	12	5/64"	Steel	31-7/8"

Two quality options available: HSS for steel up to 600 N/mm² strength (carbon steel, etc.) or HSS-SL for high strength steel (best for cutting stainless steel and hard metal). Note: Length of blade = Operating length + 5-1/4 inches. (Ex.: To cut a 10" dia. pipe use a blade with a minimum length of 16 inches.) All the above saw blades cut on backward stroke.



ING FACING FACING FACING FACING FACING FACING FACING FACING FACING
FACING FACING FACING FACING FACING FACING FACING FACING FACING FA
ING FACING FACING FACING FACING FACING FACING FACING FACING FACING

FACING PRODUCTS

TSM-1000 • 1/8" to 1" TUBE (OD MOUNT / BATTERY POWERED)

FEATURES - PORTABLE!

TSM-1000 is one of the smallest designed facing tools on the market today. The machine is powered by an air cooled 18V-Li Metabo battery motor and the total working weight of the machine is 6 lbs. The design of this machine makes it easy to use on job sites, making hard-to-reach areas easily accessible due to it's small size.

It has a battery powered motor, which will last for 2+ hours, with a 15 min. recharge. Collets are made from Stainless Steel material and are self-locking into the cutter to hold the collets in place.



Standard TSM-1000 Collets

TSM-1000 Machine Kit Includes: Machine, Tool Bits (2), Tooling, Manual and Case

TSM-1000 Kit with Variable Battery Powered Motor

P/N: TSM-1000-10-BP

TSM-1500 Kit with Variable Battery Powered Motor (230v)

P/N: TSM-1000-10-BP-230

PERFORMANCE

- Size range 1/8" to 1" Tube (3.175 mm - 25.4 mm)
- 18V Metabo air cooled Li powered battery motor
- Easy replacement of collets and size ranges
- Uses Stainless Steel collet set (upper / lower)
- 6 lbs. (2.6 kg) approximate working weight
- Faces most metals and plastics, including high nickel materials
- Battery charger: 110V;60Hz US Style / 220V;50Hz CE Compliant
- Tool bits are designed to work on the following materials: stainless steel, inconel, hastelloy, carbon steels, aluminum and other alloys
- Options: additional batteries can be purchased

TOOL BIT FOR TSM-1000 Standard tool bit for SS Material

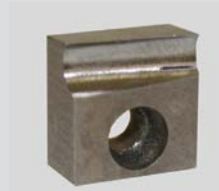

P/N: TB-1009-LC

STANDARD COLLETS

INCHES			
TSM-1001	1/8" TUBE	TSM-1005	5/8" TUBE
TSM-1002	1/4" TUBE	TSM-1006	3/4" TUBE
TSM-1003	3/8" TUBE	TSM-1007	7/8" TUBE
TSM-1004	1/2" TUBE	TSM-1008	1" TUBE / 25.4mm

MILLIMETERS			
TSM-1009	6mm TUBE	TSM-1014	13mm TUBE
TSM-1010	8mm TUBE	TSM-1015	14mm TUBE
TSM-1011	10mm TUBE	TSM-1016	18mm TUBE
TSM-1012	11mm TUBE	TSM-1017	22mm TUBE
TSM-1013	12mm TUBE	TSM-1018	25mm TUBE

FEATURES

This is our first machine and the tool that started a revolution in the field of facing tools. Our machines offer increment feed control so you can cut and debur tubing at precision lengths.

All TSM-1500 Collets are made of hard anodized aluminum for maximum hold and minimal weight. Their three-piece design ensures accurate centering while affording the most surface area contact for the greatest holding power.



Standard TSM-1500 Collets

TB-1506 Tool Bit

TSM-1500 Machine Kit Includes: Machine, Tool Bits (2), Tooling, Manual and Case

TSM-1500 Kit with Variable 110v Motor	P/N: TSM-1500-10
TSM-1500 Kit with Variable 230v Motor	P/N: TSM-1500-10-230
TSM-1500 Kit with Variable Battery Powered Motor (110V)	P/N: TSM-1500-10-BP
TSM-1500 Kit with Variable Battery Powered Motor (230v)	P/N: TSM-1500-10-BP-230

Note: Bench Mount Option Available

P/N: TSM-253

PERFORMANCE

- Size range 1/8" to 1.5" Tube (3.175 mm - 38.1 mm)
- Standard 110V variable speed motor
- Portable or mountable for high volume production
- Easy replacement of collets and size ranges
- 10 lbs. approximate working weight
- Adjustable measure indicator for accurate facing
- Large view port for easy bit replacement
- Tool bit designed to keep chips out of polished ID
- Faces most metals and plastics, including high nickel and carbon steel materials
- Options: bench mount kit or battery powered motor

TOOL BITS FOR TSM-1500

- ** TB-0169 Facing Bit (.75" Tall)
- TB-0167 37.5 degree bevel
- TB-0202 Extended reach standard facing style (1" Tall)
- TB-0202-LC Extended reach laser coated (1" Tall)
- TB-0204 Heavy duty for larger wall thickness (.75" Tall)
- * TB-1506 For use on 316 or 304 stainless steel (.75" Tall)
- * TB-1506-LC Laser coated for abrasion resistance
- TB-1510 Double sided tool insert (carbide)
- ** TB-4000 Facing Bit (.625" Tall)
- TB-5000 For soft and gummy SS tubing (.75" Tall)
- TSM-AD-1500 Tool bit adapter/holder for inserts
- * *Tool bits included in kit*
- ** *Not recommended for electropolished tube*

STANDARD COLLETS

INCHES			
TSM-000	1/8" TUBE	TSM-007	1" TUBE / 25.4mm
TSM-001	1/4" TUBE	TSM-010	1-1/2" TUBE
TSM-002	3/8" TUBE	TSM-011	1/4" PIPE
TSM-003	1/2" TUBE	TSM-012	1/2" PIPE
TSM-004	5/8" TUBE	TSM-013	3/4" PIPE
TSM-005	3/4" TUBE	TSM-014	1" PIPE
TSM-006	7/8" TUBE		

MILLIMETERS	
TSM-019	8mm TUBE
TSM-020	10mm TUBE
TSM-021	12mm TUBE
TSM-017	6mm TUBE
TSM-023	14mm TUBE
TSM-024	15mm TUBE
TSM-025	18mm TUBE
TSM-026	22mm TUBE
TSM-027	23mm TUBE
TSM-028	28mm TUBE
TSM-029	35mm TUBE

All facing machines come packaged in our heavy duty case with tooling, tool bits(2) and manual. Collets sold separately.



FACING PRODUCTS

TSM-1501M • 1/8" to 1" TUBE (OD MOUNT / ELECTRIC)

FEATURES

Our new micro facing machine was designed to face 1/8" to 1" tubing. We also offer two collets: our standard collets for facing micro fitting or short tubing from .20" long and our extended collets for 1" and above.

This new machine will let you face quickly and squarely every time. You will also find this machine has an unobstructed view of the tool bit and tubing. Stainless collets will not damage your electro-polish tubing. Our feed indicator will give you precise lengths every time.



TSM-1501M Machine Kit Includes: Machine, Tool Bits (2), Tooling, Manual and Case

TSM-1501M Kit with Variable 110v Motor	P/N: TSM-1501M-10
TSM-1501M Kit with Variable 230v Motor	P/N: TSM-1501M-10-230
TSM-1501M Kit with Variable Battery Powered Motor (110V)	P/N: TSM-1501M-10-BP
TSM-1501M Kit with Variable Battery Powered Motor (230v)	P/N: TSM-1501M-10-BP-230
<i>Note: Bench Mount Option Available</i>	P/N: TSM-253

PERFORMANCE

- Size range 1/8" to 1" Tube (3.175mm- 25.4 mm)
- Standard 110V variable speed motor
- Easy replacement of collets
- 9 lbs. approximate working weight
- Adjustable measurement indicator
- Large view port for easy bit replacement
- Faces most metals and plastics, including high nickel and carbon steel materials
- Options: bench mount kit or battery powered motor

TOOL BITS FOR TSM-1501M

- ** TB-0169 Facing Bit (.75" Tall)
- TB-0167 37.5 degree bevel
- TB-0202 Extended reach standard facing style (1" Tall)
- TB-0202-LC Extended reach laser coated (1" Tall)
- TB-0204 Heavy duty for larger wall thickness (.75" Tall)
- * TB-1506 For use on 316 or 304 stainless steel (.75" Tall)
- * TB-1506-LC Laser coated for abrasion resistance
- TB-1510 Double sided tool insert (carbide)
- ** TB-4000 Facing Bit (.625" Tall)
- TB-5000 For soft and gummy SS tubing (.75" Tall)
- TSM-AD-1500 Tool bit adapter/holder for inserts
- * *Tool bits included in kit*
- ** *Not recommended for electropolished tube*

STANDARD COLLETS

INCHES			
M1-001	1/8" TUBE	M1-005	5/8" TUBE
M1-002	1/4" TUBE	M1-006	3/4" TUBE
M1-003	3/8" TUBE	M1-008	7/8" TUBE
M1-004	1/2" TUBE	M1-007	1" TUBE /25.4mm

MILLIMETERS			
M1-011	6mm TUBE	M1-017	14mm TUBE
M1-013	8mm TUBE	M1-018	15mm TUBE
M1-014	10mm TUBE	M1-019	18mm TUBE
M1-015	12mm TUBE	M1-020	22mm TUBE

EXTENDED COLLETS

INCHES			
M2-030	1/8" TUBE	M2-034	5/8" TUBE
M2-031	1/4" TUBE	M2-035	3/4" TUBE
M2-032	3/8" TUBE	M2-038	7/8" TUBE
M2-033	1/2" TUBE	M2-036	1" TUBE /25.4mm

MILLIMETERS			
M2-039	6mm TUBE	M2-043	14mm TUBE
M2-040	8mm TUBE	M2-044	15mm TUBE
M2-041	10mm TUBE	M2-045	18mm TUBE
M2-042	12mm TUBE	M2-046	22mm TUBE

FEATURES

This new facing tool will face tubing from 1/2" to 3" and is designed like our TSM-4500M, but lighter in weight, approximately 19 lbs. This tool was designed with our Pharmaceutical contractors in mind.

Our feed knob will give you the control you need to ensure precise lengths. This machine comes with a Metabo motor with speed control that will keep the RPM constant under load. This speed control will help extend the life of your tool bits.

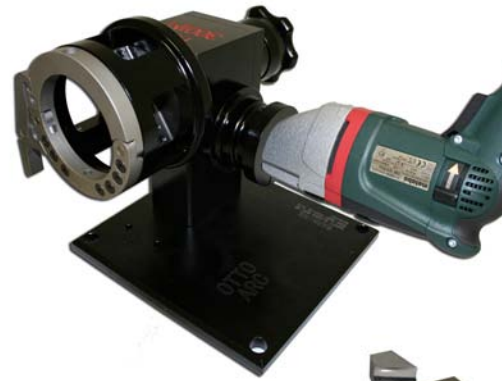

Elbow Collet for TSM-300IM



Standard Collet for TSM-300IM



Extended Collet for TSM-300IM



TB-0206 Tool Bit

TSM-300IM Machine Kit Includes: Machine, Tool Bits (2), Tooling, Manual and Case

TSM-300IM Kit with Variable Speed Control 110v Motor

P/N: TSM-300IM-10

TSM-300IM Kit with Variable 230v Motor

P/N: TSM-300IM-10-230

PERFORMANCE

- Size range .5" to 3" Tube (12.7 mm - 76.2 mm)
- Less than 20" in length and 8" in overall height
- Quick-close latching system reduces setup time
- Easy replacement of collets, various sizes
- Adjustable measurement indicator for accurate facing
- 19 lbs. approximate working weight
- Large view port for easy tool bit replacement
- Elbow collets available -face or bevel elbow fittings
- **No collet necessary for 3" tube**

Contact us for further information on our Tangent Elbow Facing Collets!

TOOL BITS FOR TSM-300IM

- TB-0167 37.5 degree bevel
- TB-0168 Counterbore bit
- ** TB-0169 Facing Bit (.75" Tall)
- TB-0202 Extended reach standard style
- TB-0202-LC Extended reach laser coated
- * TB-0206 Heavy duty for larger wall thickness
- TB-1506 For use on 316 or 304 stainless
- * TB-1506-LC Laser coated for abrasion resistance
- TB-1510 Double sided tool insert (carbide)
- ** TB-4000 Facing Bit (.625" Tall)
- TB-5000 For soft and gummy SS tubing (.75" Tall)
- TSM-AD-3000 Tool bit adapter/holder for inserts
- * *Tool bits included in kit*
- ** *Not recommended for electropolished tube*

STANDARD COLLETS

INCHES			
TSM-651	1/2" TUBE	TSM-660	2-1/2" TUBE /63.5mm
TSM-652	5/8" TUBE	TSM-662	1/2" PIPE
TSM-653	3/4" TUBE /19.05 mm	TSM-663	3/4" PIPE
TSM-654	7/8" TUBE	TSM-664	1" PIPE
TSM-655	1" TUBE /25.4mm	TSM-665	1-1/2" PIPE
TSM-658	1-1/2" TUBE /38.1mm	TSM-666	2" PIPE
TSM-659	2" TUBE /50.8mm	TSM-667	2-1/2" PIPE

MILLIMETERS			
TSM-668	12mm TUBE	TSM-675	35mm TUBE
TSM-669	13.5mm TUBE	TSM-676	52mm TUBE
TSM-670	14mm TUBE	TSM-677	57.15mm TUBE
TSM-671	15mm TUBE	TSM-678	60.5mm TUBE
TSM-672	17.2mm TUBE	TSM-679	69.85mm TUBE
TSM-673	22mm TUBE		
TSM-674	28mm TUBE		

EXTENDED COLLETS

INCHES			
TSM-601	1/2" TUBE	TSM-610	2-1/2" TUBE /63.5mm
TSM-602	5/8" TUBE	TSM-612	1/2" PIPE
TSM-603	3/4" TUBE /19.05 mm	TSM-613	3/4" PIPE
TSM-604	7/8" TUBE	TSM-614	1" PIPE
TSM-605	1" TUBE /25.4mm	TSM-615	1-1/2" PIPE
TSM-608	1-1/2" TUBE /38.1mm	TSM-616	2" PIPE
TSM-609	2" TUBE /50.8mm	TSM-617	2-1/2" PIPE

MILLIMETERS			
TSM-618	12mm TUBE	TSM-625	35mm TUBE
TSM-619	13.5mm TUBE	TSM-626	52mm TUBE
TSM-620	14mm TUBE	TSM-627	57.15mm TUBE
TSM-621	15mm TUBE	TSM-628	60.5mm TUBE
TSM-622	17.2mm TUBE	TSM-629	69.85mm TUBE
TSM-623	22mm TUBE		
TSM-624	28mm TUBE		

FACING PRODUCTS

TSM-4500M • 1" to 4.5" TUBE (OD MOUNT / ELECTRIC)

FEATURES

This lightweight 25lb. facing machine has a wide working range of 1" to 4-1/2" OD. Our facing tool offers floating collets that let you grip oversize or out-of-round tubing.

As with all our "M" style machines, we offer three types of collets. Use "Standard" to face short tube fittings and use extended collet's for tubing 4" or longer. It comes with a standard variable speed motor, allowing you to set a constant operating speed.



TB-1506 Tool Bit



Standard Collet for TSM-4500M



Extended Collet for TSM-4500M



Elbow Collet for TSM-4500M

TSM-4500M Machine Kit Includes: Machine, Tool Bits (2), Tooling, Manual and Case

TSM-4500M Kit with Variable with Speed Control 110v Motor

P/N: TSM-4500M-10

TSM-4500M Kit with Variable 230v Motor

P/N: TSM-4500M-10-230

PERFORMANCE

- Size range for pipe 1" OD to 4.5" OD (25.4 mm - 114.3 mm)
- Rugged two speed design to fit more applications
- Quick-close latching system reduces setup time
- Comes with bench stand
- Easy replacement of collets and size ranges
- Adjustable measurement indicator for accurate facing
- Large view port for easy bit replacement
- Faces high nickel and carbon steel materials
- Spring loaded collets help align out-of-round tubing
- Elbow collets available -face or bevel elbow fittings

Contact us for further information on our Tangent Elbow Facing Collets!

TOOL BITS FOR TSM-4500M

- TB-0167 37.5 degree bevel
- TB-0168 Counterbore bit
- ** TB-0169 Facing Bit (.75" Tall)
- TB-0202 Extended reach standard style
- TB-0202-LC Extended reach laser coated
- * TB-0206 Heavy duty for larger wall thickness
- TB-1506 For use on 316 or 304 stainless
- * TB-1506-LC Laser coated for abrasion resistance
- TB-1510 Double sided tool insert (carbide)
- ** TB-4000 Facing Bit (.625" Tall)
- TB-5000 For soft and gummy SS tubing (.75" Tall)
- TSM-AD-3000 Tool bit adapter/holder for inserts

* Tool bits included in kit

** Not recommended for electropolished tube

STANDARD COLLETS

INCHES			
TSM-7101	1" TUBE / 25.4mm	TSM-7109	4-1/2" TUBE (4" PIPE)
TSM-7103	1-1/2" TUBE / 38.1mm	TSM-7110	3/4" PIPE
TSM-7104	2" TUBE / 50.8 mm	TSM-7111	1" PIPE
TSM-7105	2-1/2" TUBE / 63.5mm	TSM-7112	1.5" PIPE
TSM-7106	3" TUBE / 76.2mm	TSM-7113	2" PIPE
TSM-7107	3-1/2" TUBE (3" PIPE)	TSM-7114	2.5" PIPE
TSM-7108	4" TUBE (3.5" PIPE)		

MILLIMETERS			
TSM-7119	52mm TUBE	TSM-7124	88.9mm TUBE
TSM-7120	57.15mm TUBE	TSM-7125	95.25mm TUBE
TSM-7121	60.5mm TUBE	TSM-7126	101.6mm TUBE
TSM-7122	69.85mm TUBE	TSM-7127	107.95mm TUBE
TSM-7123	82.55mm TUBE		

EXTENDED COLLETS

INCHES			
TSM-7201	1" TUBE / 25.4mm	TSM-7209	4-1/2" TUBE (4" PIPE)
TSM-7203	1-1/2" TUBE / 38.1mm	TSM-7210	3/4" PIPE
TSM-7204	2" TUBE / 50.8 mm	TSM-7211	1" PIPE
TSM-7205	2-1/2" TUBE / 63.5mm	TSM-7212	1.5" PIPE
TSM-7206	3" TUBE / 76.2mm	TSM-7213	2" PIPE
TSM-7207	3-1/2" TUBE (3" PIPE)	TSM-7214	2.5" PIPE
TSM-7208	4" TUBE (3.5" PIPE)		

MILLIMETERS			
TSM-7215	52mm TUBE	TSM-7222	101.6mm TUBE
TSM-7216	57.15mm TUBE	TSM-7223	107.95mm TUBE
TSM-7217	60.5mm TUBE		
TSM-7218	69.85mm TUBE		
TSM-7219	82.55mm TUBE		
TSM-7220	88.9mm TUBE		
TSM-7221	95.25mm TUBE		

FEATURES - HOLDS 3 TOOL BITS! FACES, BEVELS AND COUNTERBORES!

This lightweight 42 lb. facing machine has a wide working range of 1" to 6.625" OD. With our machine you do not have to change adapters if you change tubing size.

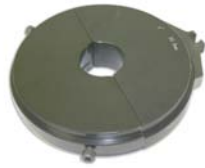

Standard Collet for TSM-6000



TB-0206 Tool Bit



TSM-6000 Machine Kit Includes: Machine, Tool Bits (2), Tooling, Manual and Case

TSM-6000 Kit with Variable Speed Control 110v Motor

P/N: TSM-6000-10

TSM-6000 Kit with Variable 230v Motor

P/N: TSM-6000-10-230

PERFORMANCE

- Size range for pipe 1.315" OD to 6.625" OD
- Size range for tube 1" to 6"
- Rugged two speed design to fit more applications
- Quick-close latching system reduces setup time
- Comes with bench stand
- Adjustable measurement indicator for accurate facing
- Large view port for easy bit replacement
- Faces most metals and plastics, including high nickel and carbon steel materials

TOOL BITS FOR TSM-6000

- TB-0167 37.5 degree bevel
- TB-0168 Counterbore bit
- ** TB-0169 Facing Bit (.75" Tall)
- TB-0202 Extended reach standard style
- TB-0202-LC Extended reach laser coated
- * TB-0206 Heavy duty for larger wall thickness
- TB-1506 For use on 316 or 304 stainless
- * TB-1506-LC Laser coated for abrasion resistance
- TB-1510 Double sided tool insert (carbide)
- ** TB-4000 Facing Bit (.625" Tall)
- TB-5000 For soft and gummy SS tubing (.75" Tall)
- TSM-AD-3000 Tool bit adapter/holder for inserts
- * *Tool bits included in kit*
- ** *Not recommended for electropolished tube*

STANDARD COLLETS

INCHES			
TSM-6001	1" TUBE / 25.4mm	TSM-6009	3" TUBE / 76.2mm
TSM-6002	1" PIPE	TSM-6010	3-1/2" TUBE (3" PIPE) / 88.9mm
TSM-6003	1-1/2" TUBE / 38.1mm	TSM-6011	4" TUBE (3.5" PIPE) / 101.6mm
TSM-6004	1-1/2" PIPE	TSM-6012	4.1/4" TUBE / 107.95mm
TSM-6005	2" TUBE / 50.8 mm	TSM-6013	4-1/2" TUBE (4" PIPE) / 114.3mm
TSM-6006	2" PIPE	TSM-6014	5" TUBE / 127mm
TSM-6007	2-1/2" TUBE / 63.5mm	TSM-6015	6" TUBE / 152.4mm
TSM-6008	2-1/2" PIPE	TSM-6016	6" PIPE

MILLIMETERS	
TSM-6017	28mm TUBE
TSM-6018	35mm TUBE
TSM-6019	52mm TUBE
TSM-6020	57.15mm TUBE
TSM-6021	60.5mm TUBE
TSM-6022	69.85mm TUBE
TSM-6023	76.2mm TUBE
TSM-6024	82.55mm TUBE
TSM-6025	95.25mm TUBE

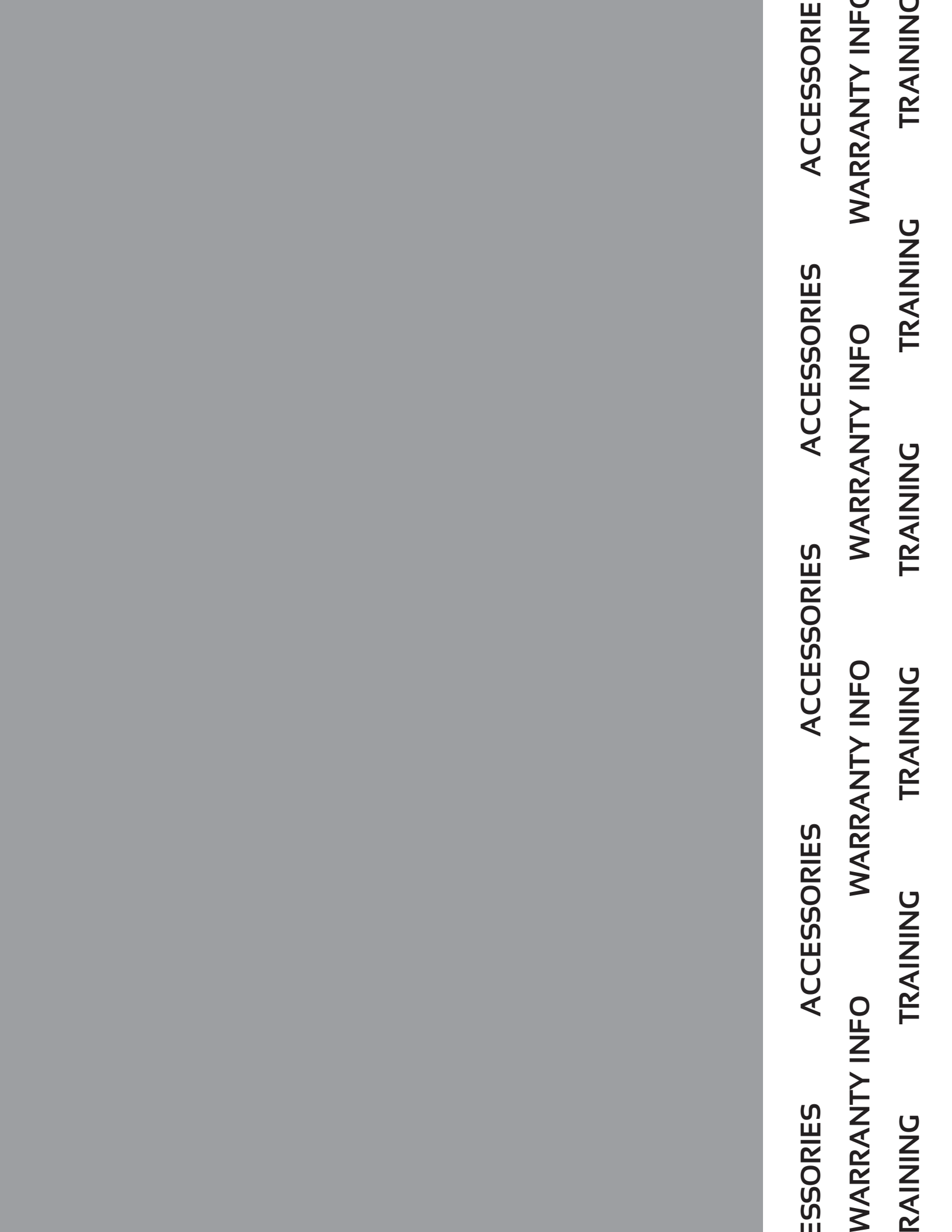

SAW GUIDES, BLADES, AIR CADDY

ADJUSTABLE SAW GUIDE - AN OTTO ARC EXCLUSIVE!

The Otto Arc Saw Guides are designed with multiple sizes in one and include 17-4 hardened steel guides that will assist in keeping the saw blade straight for square cuts plus less chance of accidentally sawing into the guide itself.



SG-1500

SG-3000

SG-6000

SAW GUIDES	PART NUMBER
.5" - 1.5" Pipe or Tube	P/N: SG-1500
1.5" - 3" Pipe or Tube	P/N: SG-3000
2" - 6" Pipe or Tube	P/N: SG-6000

Note: The SG-1500 & SG-3000 can be used with a hack saw or portaband saw. Our SG-6000 must be used with a Sawzall.



Pictured: example using Saw Guide to cut pipe/tube

SAW BLADES FOR CUTTING STAINLESS TUBING

(ALSO FITS GF STYLE MACHINES)

SAW BLADES	TEETH	PART NUMBER
.25" - .5" Tube	150	P/N: QC-150
.5" - 1" Tube	100	P/N: QC-100
1" - 3" Tube	70	P/N: QC-70
2" - 4" Pipe (.120 Wall Max.)	44	P/N: QC-44
2" - 4" Pipe (.375 Wall Max.)	32	P/N: QC-32



*QC-44 Saw Blade
(Blades can be requested with Laser Coating)*

AIR CADDY

The air caddy is optional, but highly recommended if you are using a machine with an air motor. The air caddy helps keep extra moisture out of the machine/motor as well as helping to keep it clean and extend the life of the machine. Our air caddy includes an air filter, oiler, mister and regulator.

AIR CADDY	PART NUMBER
Recommended for air motors	P/N: PBM-AF



AMI WELD HEADS

Otto Arc aftermarket orbital welding collets for Arc Machine weld heads are made to the highest quality standards. All our collets are made from stainless steel to give you better wear versus aluminum type collets. Our new spring designed collet will hold oversized and undersized tubing. Our new spring collets have more flexibility to hold all types of tubing or pipe. Our 500 heads now offer gate screws with springs to hold the latch up to make closing the upper gate easier. Our one-piece construction on the lower head will give you better alignment on both sides of your tubing.

500 HEAD *Note: This head come as a cassette, you only need one to complete the entire head.*

P/N for 500 Head	Size
500-125	.125" Tube
500-25	.25" Tube
500-375	.375" Tube
500-5	.5" Tube

Accessories and Parts for 500 Head	
500-Window	Replacement window
500-WI	Replacement window screws
500-Screw	Replacement thumb screw for 9-500 head (old)
500-Screw-I	Replacement thumb screw for 9-500 head (new)
500-Holder	Orbital welding head holders

750 HEAD

P/N for 750 Head	Size
753-125	.125" Tube
753-25	.25" Tube
753-375	.375" Tube
753-5	.5" Tube
753-625	.625" Tube
753-75	.75" Tube

Accessories and Parts for 750 Head	
750-Window	Replacement window
750-WI	Replacement window screws
750-SI	Replacement SS collet screws
750-Screw	Replacement thumb screw for 9-750 head
750-Holder	Orbital welding head holders

1500 HEAD

P/N for 1500 Head	Size	1500 Head	Size
1503-25	.25" Tube	1503-1.25	1.25" Tube
1503-375	.375" Tube	1503-1.5	1.5" Tube
1503-5	.5" Tube	1503-5P	.5" Pipe
1503-625	.625" Tube	1503-75P	.75" Pipe
1503-75	.75" Tube	1503-1P	1" Pipe
1503-1	1" Tube		

2000 HEAD

P/N for 2000 Head	Size	2000 Head	Size
2003-5	.5" Tube	2003-5P	.5" Pipe
2003-75	.75" Tube	2003-375P	.375" Pipe
2003-1	1" Tube	2003-75P	.75" Pipe
2003-1.5	1.5" Tube	2003-1P	1" Pipe
2003-2	2" Tube	2003-1.5P	1.5" Pipe

2500 HEAD

P/N for 2500 Head	Size	2500 Head	Size
2503-75	.75" Tube	2503-75P	.75" Pipe
2503-1	1" Tube	2503-1P	1" Pipe
2503-1.5	1.5" Tube	2503-1.5P	1.5" Pipe
2503-2	2" Tube	2503-2P	2" Pipe
2503-2.5	2.5" Tube		

3500 HEAD

P/N for 3500 Head	Size	3500 Head	Size
3503-1	1" Tube	3503-1.5P	1.5" Pipe
3503-1.5	1.5" Tube	3503-2P	2" Pipe
3503-2	2" Tube	3503-2.5P	2.5" Pipe
3503-2.5	2.5" Tube	3503-3.5	3.5" Tube (3" Pipe)
3503-3	3" Tube		

NOTE: All AFTERMARKET collets and tool bits are manufactured by Otto Arc Systems, Inc. and are not genuine Tri Tool, George Fisher, Orbatek, ARC Machine or Swagelok products. Each is a trademark of its own.



500 Cassette Head



750 Head

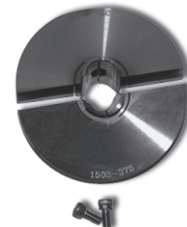

1500 Head



2000 Head

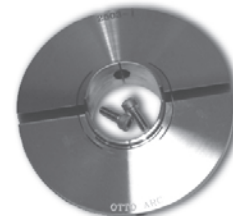

2500 Head



3500 Head

ACCESSORIES

AMI ORBITAL WELDING & AFTERMARKET PRODUCTS

AMI WELD HEADS continued

4000 HEAD			
P/N for 4000 Head	Size	4000 Head	Size
4003-1	1" Tube	4003-3.5	3.5" Tube (3" Pipe)
4003-1.5	1.5" Tube	4003-4	4" Tube (3.5" Pipe)
4003-2	2" Tube	4003-4.5	4.5" Tube (4" Pipe)
4003-2.5	2.5" Tube	4003-2P	2" Pipe
4003-3	3" Tube	4003-2.5P	2.5" Pipe

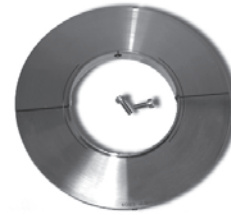

4000 Head

4500 HEAD			
P/N for 4500 Head	Size	4500 Head	Size
4503-1	1" Tube	4503-3.5	3.5" Tube (3" pipe)
4503-1.5	1.5" Tube	4503-4	4" Tube (3.5" Pipe)
4503-2	2" Tube	4503-4.5	4.5" Tube (4" Pipe)
4503-2.5	2.5" Tube	4503-2P	2" Pipe
4503-3	3" Tube	4503-2.5P	2.5" Pipe

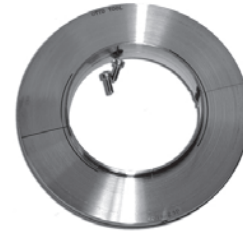

4500 Head

7500 HEAD	
P/N for 7500 Head	Size
7503-3.5	3.5" Tube (3" Pipe)
7503-4	4" Tube (3.5" Pipe)
7503-4.5	4.5" Tube (4" Pipe)
7503-6	6" Tube
7503-6P	6" Pipe



7500 Head

AFTERMARKET PRODUCTS

REPLACEMENT PRINTER PAPER	
OW-1000	Printer paper for #207 machine
OW-ARC	Printer paper for OW-ARC Power Units

TRI TOOL FACING TOOL BITS		
TRI TOOL P/N:	OTTO ARC P/N:	DESCRIPTION:
Durabit-1	TB-1506-LC	Laser Coated Facing Bit
99-1046	TB-1046	Heavy Duty Facing Bit
99-1506	TB-1506	Facing Bit
99-1506-LC	TB-1506LC	Laser Coated Facing Bit
99-1445C	TB-1445C	Carbide Facing Bit
99-5000	TB-5000	Extended Reach Facing Bit
99-5176	TB-5176	Extended Reach Facing Bit

TOOL BIT FOR GEORGE FISHER/ORBITALUM FACING MACHINE	
TB-1510	Double Sided Tool Bit for RPG Series

TOOL BIT FOR SWAGELOK FACING MACHINE	
TB-SL-01	Facing Bit

TOOL BIT FOR T&C FACING MACHINE	
TB-1111	Double Sided Tool Bit

TRI TOOL SEVER / CUT OFF BITS		
TRI TOOL P/N:	OTTO ARC P/N:	DESCRIPTION:
99-2959	TB-2959	For 572 Facing Tool
99-3143	TB-3143	For 574 Facing Tool
99-3347	TB-3347	For 574 Facing Tool
99-5472	TB-5472	For 576 Facing Tool



TB-5472 Sever Bit

TRI TOOL 301 FACING COLLETS		
TRI TOOL P/N:	OTTO ARC P/N:	SIZE:
30-0065	301-E-0065	.25" Collet
30-0066	301-E-0066	0.375" Collet
30-0067	301-E-0067	.5" Collet
30-0068	301-E-0068	0.625" Collet
30-0069	301-E-0069	0.75" Collet
30-0070	301-E-0070	1" Collet



301-E-0067 Collet

TRI TOOL 301 SADDLE COLLETS			
EXTENDED	SIZE:	SHORT PERCH	SIZE:
30ISS-125	0.125"	30ISP-125	0.125"
30ISS-25	0.25"	30ISP-25	0.25"
30ISS-375	0.375"	30ISP-375	0.375"
30ISS-5	0.5"	30ISP-5	0.5"
30ISS-625	0.625"	30ISP-625	0.625"
30ISS-75	0.75"	30ISP-75	0.75"
30ISS-1	1"	30ISP-1	1"
30ISS-5P	.5" Pipe	30ISP-5P	.5" Pipe
30ISS-75P	.75" Pipe	30ISP-75P	.75" Pipe

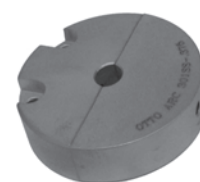

30ISS-375 Extended Collet



30ISP-5 Short Perch Collet

NOTE: All AFTERMARKET collets and tool bits are manufactured by Otto Arc Systems, Inc. and are not genuine Tri Tool, George Fisher, Orbatech, ARC Machine or Swagelok products. Each is a trademark of its own.

PRODUCT WARRANTY: All Otto Arc machines have a one year warranty starting from the date of purchase. This does not include tool bits or other consumable items.

WARRANTY DOES NOT APPLY IF:

- Repairs or attempted repairs have been made by persons other than Otto Arc personnel or authorized service repair personnel
- Repairs are required because of normal wear and tear
- The machine has been abused or involved in an accident
- Misuse is evident, such as damaged caused by overloading the machine beyond the rated capacity; if the tool has been used after partial failure; or if the tool/machine has been used with an improper accessory.
- Air motor will not be covered if damage is caused by not using oiler or mister while using

TRAINING ON-SITE / OFF-SITE: Training is available at Otto Arc Systems, Inc. or at the buyer's location (facility).

Training at Customer's Location: Normal work day is 8 hours per day Monday thru Friday. If overtime is required, it is billed at our overtime rate. Customer is responsible for all field technician costs.

Rates for field technician will be billed at the following rate:

- a) Weekday Rate: per hour - Min- 4 hours
- b) Weekend Rate: per hour - Min- 8 hours
- c) Overtime Rate (after 8hrs.): 1.5 times regular rate
- d) Weekend Stay: flat rate per day
- e) US Holiday: flat rate per day
- f) Travel Day: per hour
- g) Travel Charges: Air fare, ground transportation and hotel cost shall be billed at actual cost. Meals shall be billed out at cost determined per day. If technician is required to drive to the customer's location, facility or job site mileage will be billed per mile, plus cost for tolls
- h) Training Delays: If field tech is at job site and unable to work due to weather, power loss, missing equipment, etc. per day charge will apply

Training at Otto Arc Systems, Inc. Location:

Normal work day is 8 hours per day Monday thru Friday. Normal hours are 8am to 5pm with 1 hour lunch. Training is billed per day. Overtime will be billed at per hour charge. All weekends are billed at determined per hour cost.

Customer's Responsibilities:

- It is the customer's responsibility to have all required equipment set up and ready for technician
- Customer is responsible for assuring the availability of power and that it is working properly, gases at point of utilization, coolant for welders and any other necessary items required to get equipment running
- Otto Arc will be able to provide assistance in some of these areas, but does not take any responsibility for them
- At no time is Otto Arc personally responsible for any equipment, or damage done by other persons during training or while at the customer's job site or location

Please note that these Terms & Conditions can be changed at any time pending on your company's needs and requirements. Please contact Otto Arc Systems, Inc. for further details or questions regarding these terms and conditions.

RENTALS: Renting our machines is also a chance to see first-hand, the quality of our equipment! At Otto Arc Systems, Inc. we provide our customers with the option to rent equipment. Our rental prices are based on a weekly or monthly rental. We also have a "rent to own" option for our customers who would like to purchase the particular equipment rented, our minimum rental period is one week. Training on Otto Arc rental equipment is also available.

For further details on our rental program, please contact your sales representative or call our office direct.



www.ottoarc.com

Distributor/Sales Representative Information:

[Empty rounded rectangular box for distributor information]

OTTO ARC SYSTEMS, INC. (USA)

3921 Sandstone Drive • El Dorado Hills, CA • 95762

Phone: 916-939-3400 • Fax: 916-939-0912 • Toll Free: 800-878-2487

OTTO ARC SYSTEMS, INC. (CHINA)

A 4th Floor • Block 2 • 398 Tian Lin Road • Shanghai, China • Postcode 200233

Phone: 0086 (0)21-5490 2005/6 • Fax: 0086 (0)21-5418 6067